

**CODING**  
- 522047



ISO 9001:2015  
Reg. No. 000435-1-MY-1-QMS

**nuhoom.com**

Read the instructions carefully. Remove all the wrappings, staples and straps from the carton. Refer to the hardware and furniture part list for guidance. Make sure that you have all the parts before you start assembling. Place all the wooden furniture parts on a clean, flat and soft surface, such as a carpet or rubbermat to prevent scratches.

CAUTION  
KEEP ALL THE PARTS OUT OF CHILDREN'S REACH.

PART LIST		QTY
1	TOP PANEL	1 PC
2	BOTTOM PANEL	1 PC
3	SIDE PANEL (L)	1 PC
4	SIDE PANEL (R)	1 PC
5	CENTER PANEL	1 PC
6	MIDDLE PANEL	2 PCS
7	BONE PANEL	2 PCS
8	SHELF PANEL	6 PCS
9	BACK PANEL	1 PC
10	DOOR PANEL (L)	1 PC
11	DOOR PANEL (R)	1 PC
12	LEG	4 PCS

HARDWARE			
A	MINI FIX	A1  A2  A3	14 PCS
B	M8 X 30MM WOOD DOWEL		28 PCS
C	M6 X 50MM CSK CAP WOOD SCREW		6 PCS
D	5/8 NAIL		38 PCS
E	ALLEN KEY M4		1 PC
F	ONE HOLE L BRACKET (2MM)		4 PCS
G	M3.5 X 16MM C.B SCREW		32 PCS
H	SOFT CLOSING 7/8 HINGES		4 PCS
I	METAL SHELF SUPPORT		24 PCS
J	JCBC Screw M6 x 70		8 PCS
K	SPRING WASHER M6		8 PCS
L	FLAT WASHER M6		8 PCS
M	TIPPING PACK WITHOUT AI	M1  M2  M3  M4  M5	2 SETS

SELF-PREPARED TOOLS: Tools below are NOT included in package.	
SCREWDRIVER	HAMMER

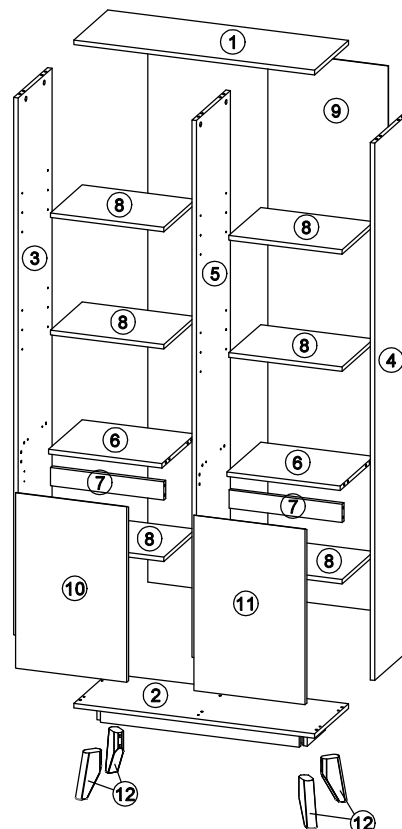

**CODING**  
- 522047



ISO 9001:2015  
Reg. No. 000435-1-MY-1-QMS

nuhoom.com

**STEP 1**

- Insert hardware **A2** onto panel (1).  
(Repeat 6 times.)

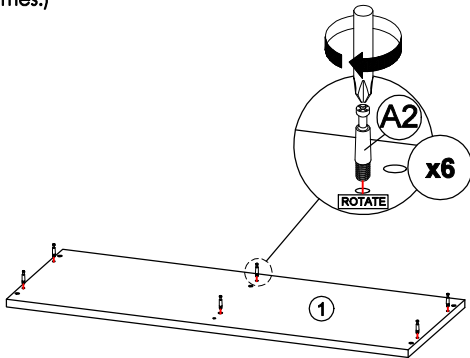

**STEP 2**

- Insert hardware **A1** onto panel (3) and (4).  
(Repeat 4 times.)
- Insert hardware **A2** onto panel (3) and (4).  
(Repeat 4 times.)
- Insert hardware **B** onto panel (3) and (4).  
(Repeat 8 times.)

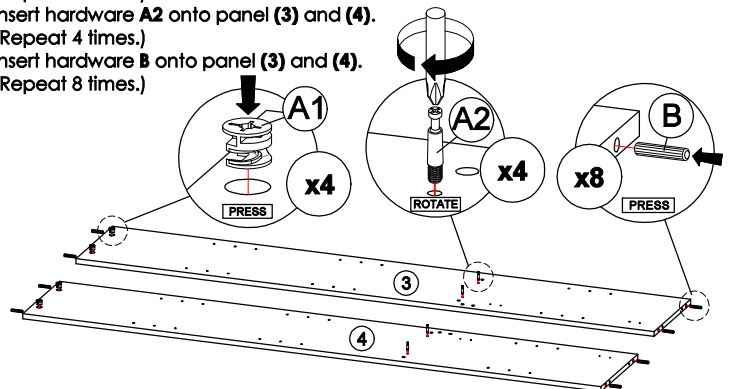

\* Ensure the arrows on hardware **A1** point towards mounting positions.

**STEP 3**

- Insert hardware **A1** onto panel (5).  
(Repeat 2 times.)
- Insert hardware **A2** onto panel (5).  
(Repeat 4 times.)
- Insert hardware **B** onto panel (5).  
(Repeat 4 times.)

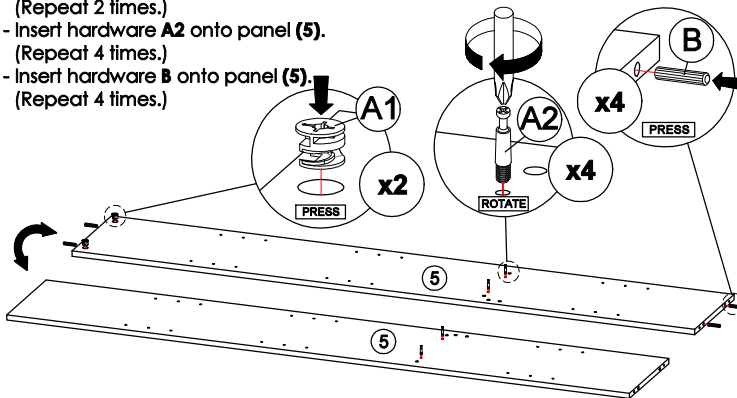

\* Ensure the arrows on hardware **A1** point towards mounting positions.

**STEP 4**

- Insert hardware **A1** onto panel (6).  
(Repeat 4 times on each panel.)
- Insert hardware **B** onto panel (6).  
(Repeat 4 times on each panel.)

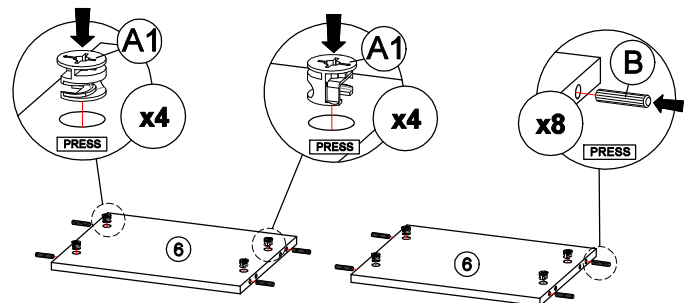

\* Ensure the arrows on hardware **A1** point towards mounting positions.

**STEP 5**

- Assemble hardware **F** to panel (7) with hardware **G**.  
(Repeat 2 times on each panel.)
- Insert hardware **B** onto panel (7).  
(Repeat 4 times on each panel.)

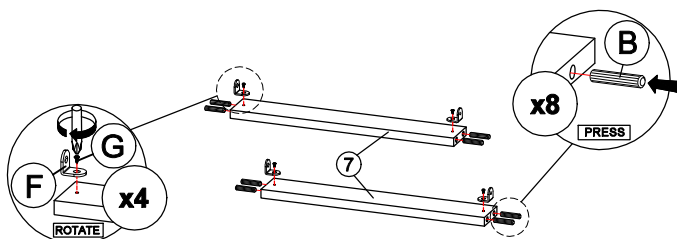

**STEP 6**

- Attach panel (6) to panel (5).
- Insert all hardware **A2** into **A1**.
- Rotate all **A1** until tight.
- Apply **A3** onto all **A1**.  
(Repeat 4 times.)
- Attach panel (7) to panel (5).  
(Repeat 2 times.)



OR

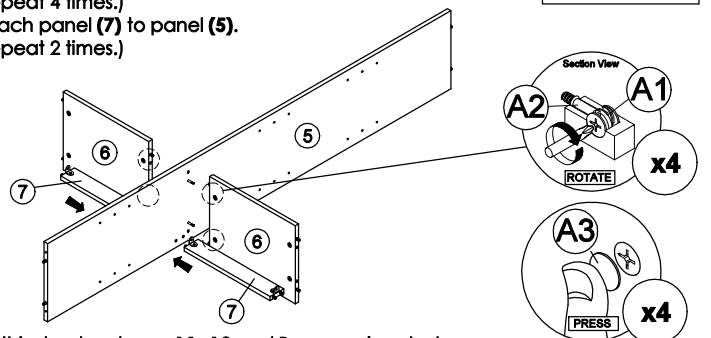

\* In this step hardware **A1**, **A2** and **B** are pre-inserted.

**CODING**  
- 522047



ISO 9001:2015  
Reg. No. 000436-1-MY-1-QMS

nuhoom.com

**STEP 7**

- Attach panel (6) to panel (3) and (4).
- Insert all hardware A2 into A1.
- Rotate all A1 until tight.
- Apply A3 onto all A1.
- (Repeat 4 times.)
- Attach panel (7) to panel (3) and (4).
- (Repeat 2 times.)

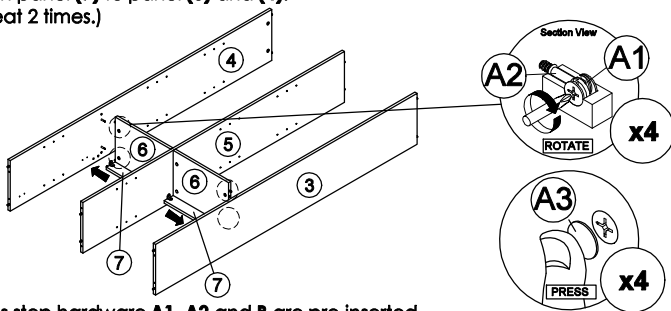
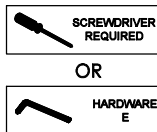

\* In this step hardware A1, A2 and B are pre-inserted.

**STEP 9**

- Connect panel (2) to panel (3), (4) and (5) by using hardware C and E.
- (Repeat 6 times.)

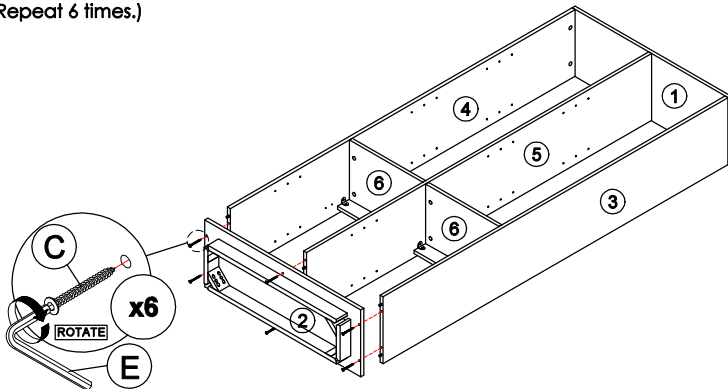

\* In this step hardware B are pre-inserted.

**STEP 11**

- Assemble part 12 into panel (2) by using hardware E, J, K and L.
- (Repeat 2 times for each Leg.)

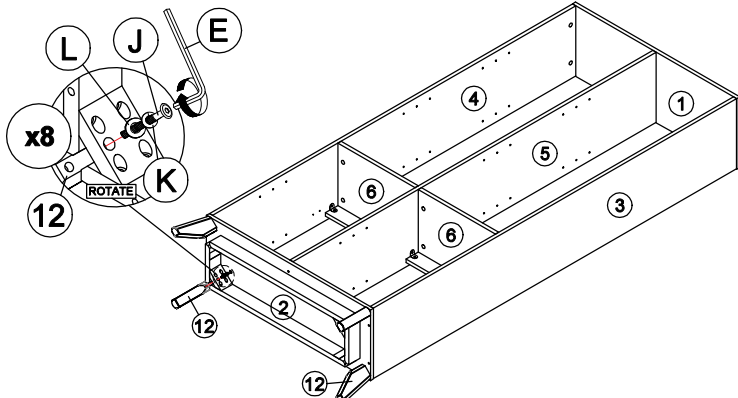

**STEP 8**

- Attach panel (3), (4) and (5) to panel (1).
- Insert all hardware A2 into A1.
- Rotate all A1 until tight.
- Apply A3 onto all A1.
- (Repeat 6 times.)

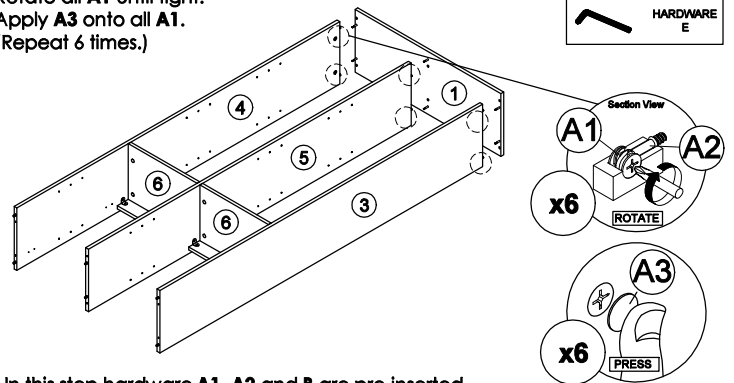
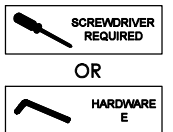

\* In this step hardware A1, A2 and B are pre-inserted.

**STEP 10**

- Assemble hardware F on panel (7) to panel (3) and (5) by using hardware G.
- Assemble hardware F on panel (7) to panel (4) and (5) by using hardware G.
- (Repeat 1 times on each side panel.)

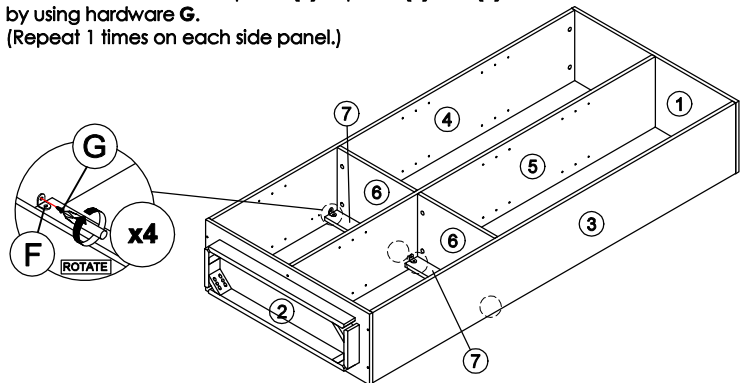

**STEP 12**

- Assemble panel (9) to entire body with hardware D.
- (Repeat 38 times.)

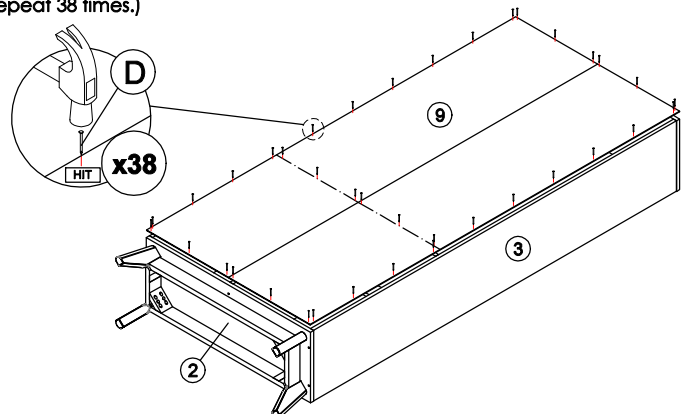

**CODING**  
- 522047



ISO 9001:2015  
Reg. No. 000435-1-MY-1-QMS

nuhoom.com

**STEP 13**

Insert hardware I into mounting positions on panel (3), (4) and (5) by hand.  
(Repeat 24 times.)

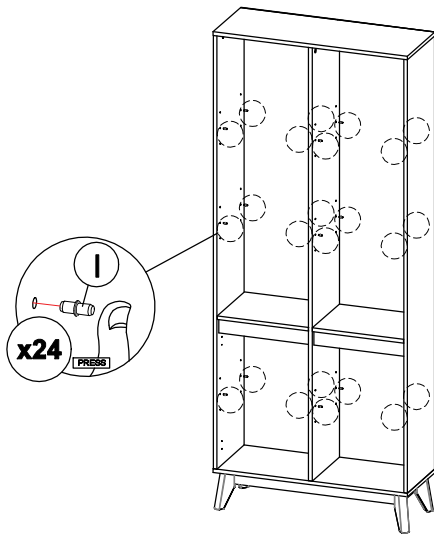

**STEP 14**

- Assemble the panel (8) into between panel (3) and (5).  
(Repeat 3 times.)
- Assemble the panel (8) into between panel (4) and (5).  
(Repeat 3 times.)

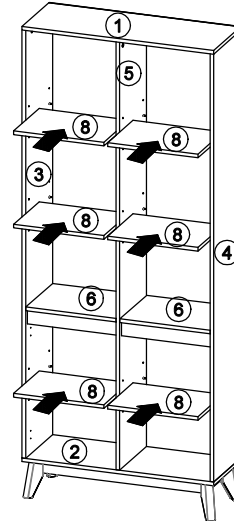

**STEP 15**

Fix hardware H onto panel (10) and (11) by using hardware G.  
(Repeat 2 times for each hardware.)

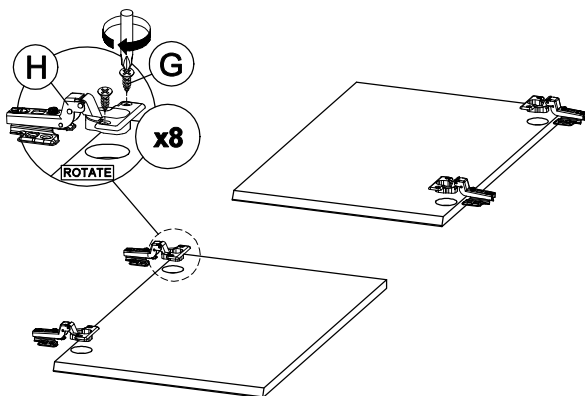

**STEP 16**

- Fix hardware H into panel (3) and (4) by using hardware G.  
(Repeat 4 times for each hardware.)
- Tighten or loosen the screw to adjust position of panel (10) and (11).  
(Do only when needed.)

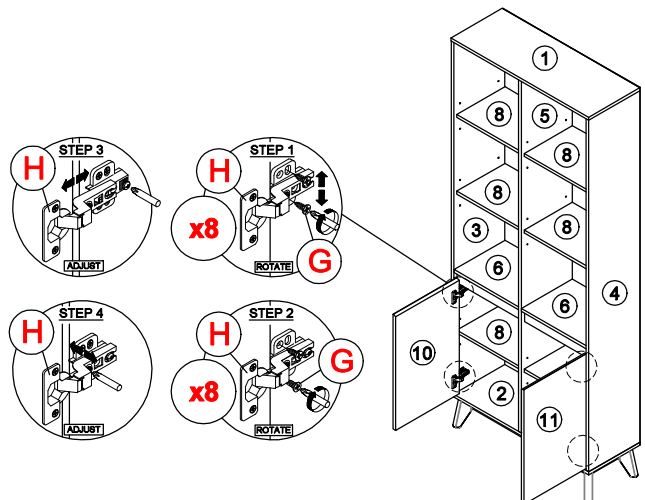

\* In this step hardware H have been assembled in panel (10) and (11).

**CODING**  
- 522047

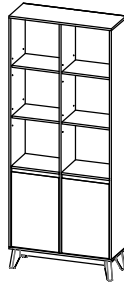

ISO 9001:2015  
Reg. No. 000435-1-MY-1-QMS

nuhoom.com

**STEP 17**

Assemble hardware **M1** into panel **(1)** and **(9)** by using hardware **M2**.  
(Repeat **2** times.)

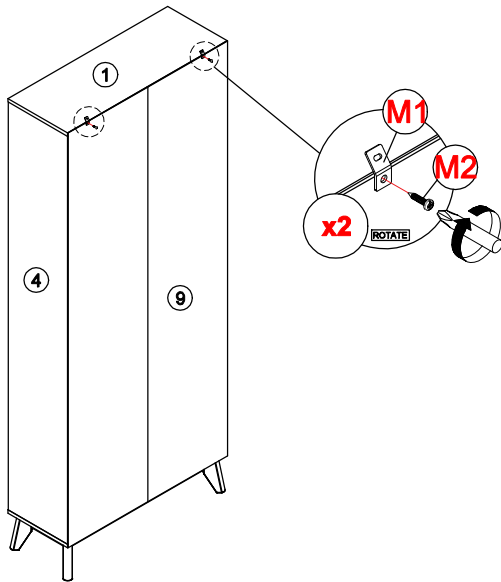

**STEP 18**

- Mark and use the power drill to drill a hole on the wall.  
- Hit hardware **M3** into the wall.  
(Repeat **2** times.)

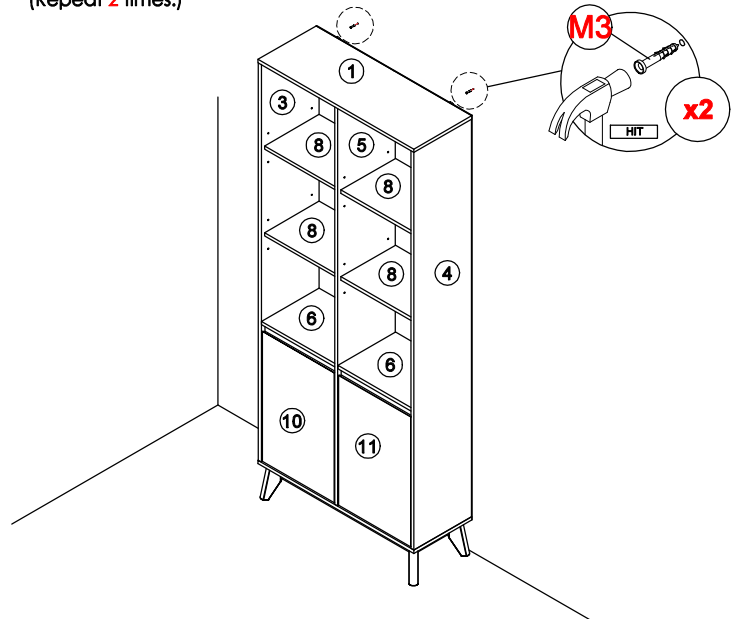

**STEP 19**

Assemble hardware **M1** to **M3** by using hardware **M4**.  
(Repeat **2** times.)

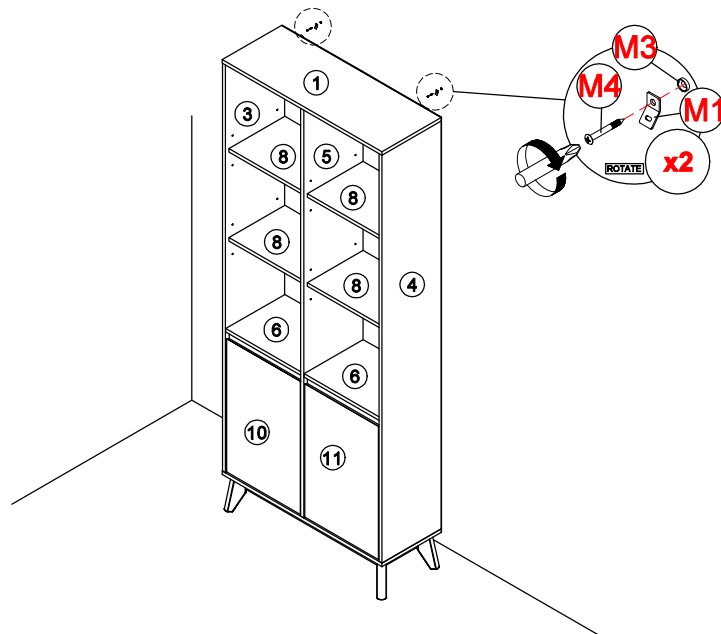

**STEP 20**

- Connect both of the hardware **M1** by using hardware **M5**.  
- Tighten the hardware **M5**.  
(Repeat **2** times.)

