

CODING
- 522044

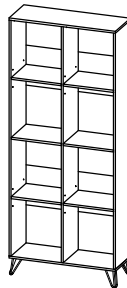

ISO 9001:2015
Reg. No. 00005-1-MY-1-QMS

nuhoom.com

Read the instructions carefully. Remove all the wrappings, staples and straps from the carton. Refer to the hardware and furniture part list for guidance. Make sure that you have all the parts before you start assembling. Place all the wooden furniture parts on a clean, flat and soft surface, such as a carpet or rubbermat to prevent scratches.

CAUTION
KEEP ALL THE PARTS OUT OF CHILDREN'S REACH.

HARDWARE				
A	MINI FIX	A1 A2 A3		14 PCS
B	M8 X 30MM WOOD DOWEL			20 PCS
C	M6 X 50MM CSK CAP WOOD SCREW			6 PCS
D	M3.5 X 16MM C.B SCREW			16 PCS
E	METAL LEG 90 x 90 x 8 x H145MM			4 PCS
F	METAL SHELF SUPPORT			16 PCS
G	5/8 NAIL			38 PCS
H	ALLEN KEY M4			1 PC
I	TIPPING PACK WITHOUT AI	11 12 13 14 15		2 SETS

SELF-PREPARED TOOLS: Tools below are NOT included in package.	
SCREWDRIVER	HAMMER
POWER DRILL	

PART LIST		QTY
1	TOP PANEL	1 PC
2	BOTTOM PANEL	1 PC
3	SIDE PANEL (L)	1 PC
4	SIDE PANEL (R)	1 PC
5	CENTER PANEL	1 PC
6	MIDDLE PANEL (L)	1 PC
7	MIDDLE PANEL (R)	1 PC
8	BACK PANEL	2 PCS
9	SHELF PANEL	4 PCS

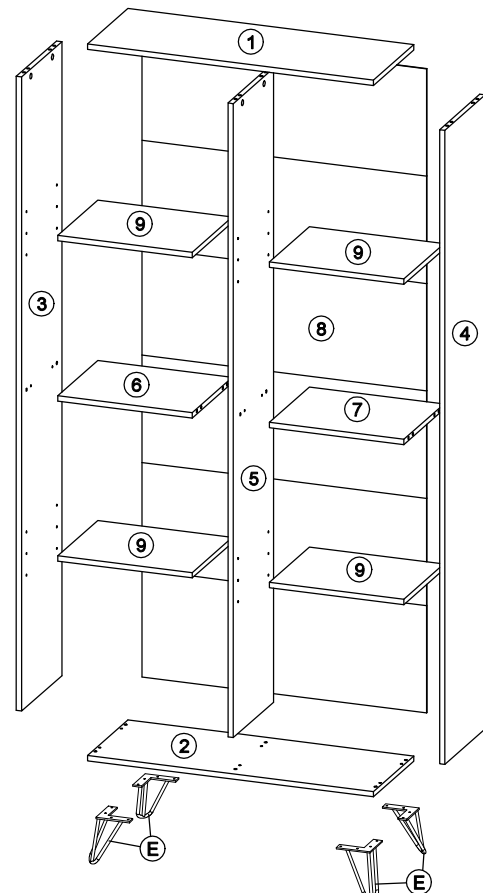

CODING
- 522044



ISO 9001:2015
Reg. No. 00035-1-MY-1-QMS

nuhoom.com

STEP 1

Insert hardware **A2** onto panel **(1)**.
(Repeat 6 times.)

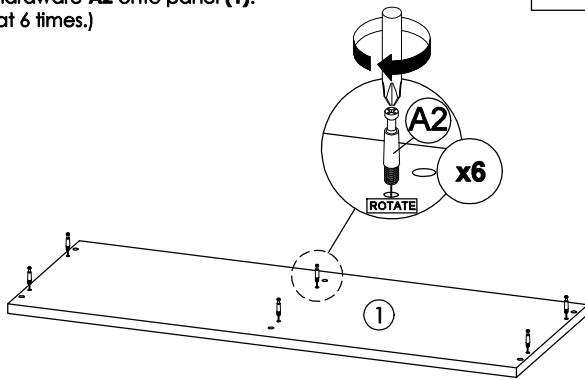

STEP 2

- Insert hardware **A1** onto panel **(3)**. (Repeat 2 times.)
- Insert hardware **A2** onto panel **(3)**. (Repeat 2 times.)
- Insert hardware **B** onto panel **(3)**. (Repeat 4 times.)

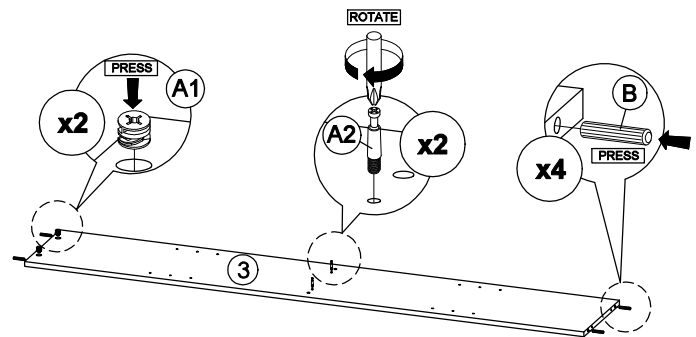

STEP 3

- Insert hardware **A1** onto panel **(4)**. (Repeat 2 times.)
- Insert hardware **A2** onto panel **(4)**. (Repeat 2 times.)
- Insert hardware **B** onto panel **(4)**. (Repeat 4 times.)

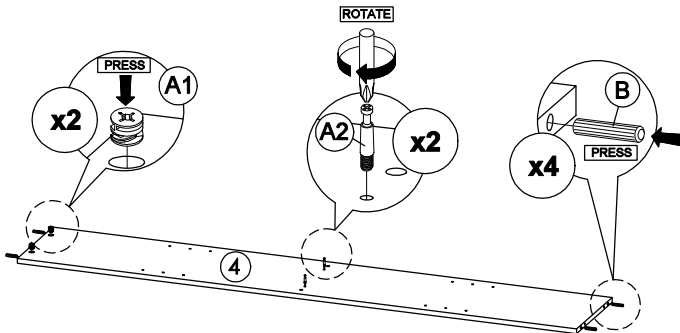

STEP 4

- Insert hardware **A1** onto panel **(5)**. (Repeat 2 times.)
- Insert hardware **A2** onto both side of panel **(5)**. (Repeat 4 times.)
- Insert hardware **B** onto panel **(5)**. (Repeat 4 times.)

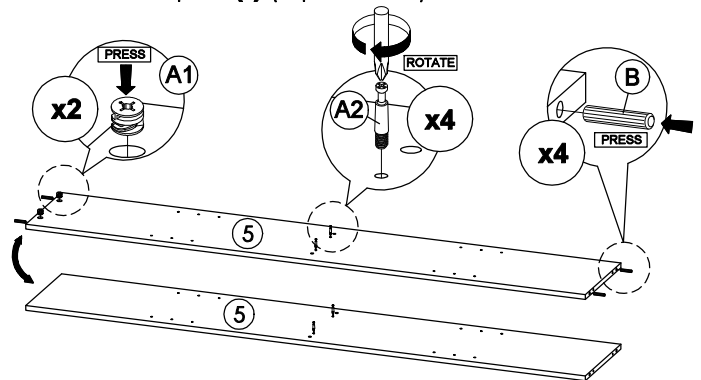

STEP 5

- Insert hardware **A1** onto panel **(6)** and **(7)**. (Repeat 8 times.)
- Insert hardware **B** onto panel **(6)** and **(7)**. (Repeat 8 times.)

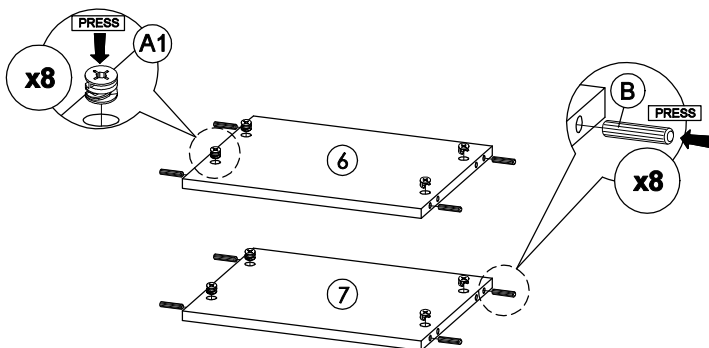

STEP 6

- Connect **A2** from panel **(5)** into **A1** in panel **(6)** and **(7)**.
- Rotate all **A1** until tight.
- Apply **A3** onto all **A1**.
(Repeat 4 times.)



OR

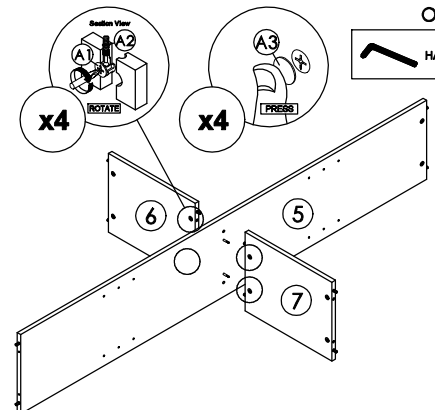
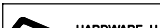

CODING
- 522044

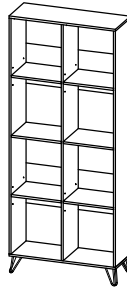

ISO 9001:2015
Reg. No. 00035-1-MY-1-QMS

nuhoom.com

STEP 7

- Connect **A2** from panel **(3)** and **(4)** into **A1** in panel **(6)** and **(7)**.
- Rotate all **A1** until tight.
- Apply **A3** onto all **A1**.
(Repeat 4 times.)

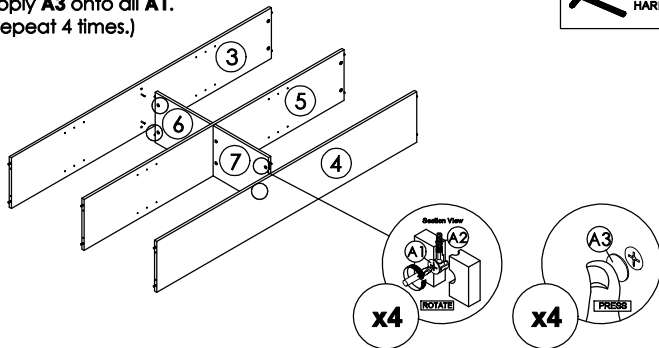
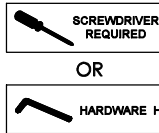

STEP 8

- Connect **A2** from panel **(1)** into **A1** in panel **(3)**, **(4)** and **(5)**.
- Rotate all **A1** until tight.
- Apply **A3** onto all **A1**.
(Repeat 6 times.)

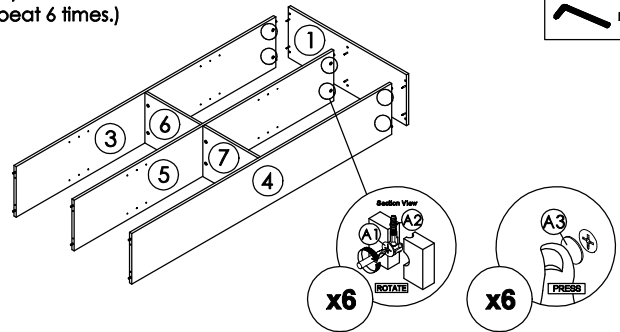
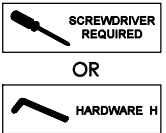

STEP 9

- Connect panel **(2)** to panel **(3)**, **(4)** and **(5)** by using hardware **C** and **H**.
(Repeat 6 times.)

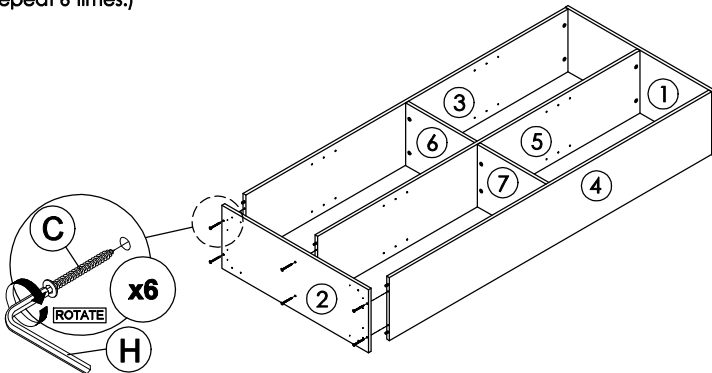

STEP 10

- Assemble hardware **E** onto panel **(2)** by using hardware **D**.
(Repeat 4 times for each hardware.)

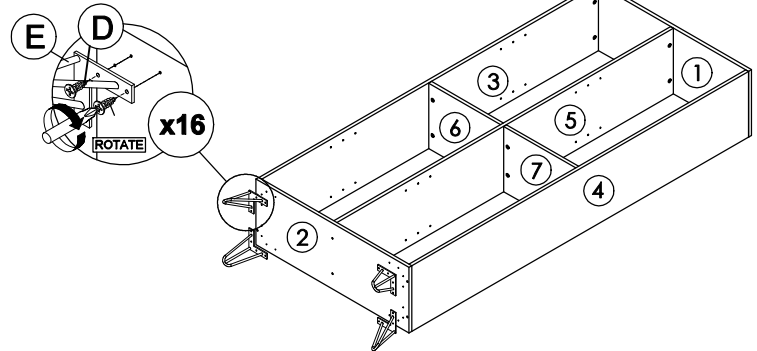

STEP 11

- Hit hardware **G** into back of panel **(8)**.
(Repeat 38 times.)

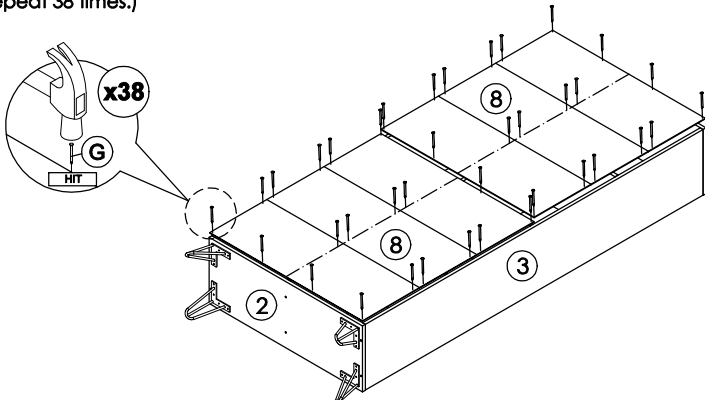

STEP 12

- Fix hardware **F** into panel **(3)**, **(4)** and **(5)**.
(Repeat 16 times.)
- Assemble the panel **(9)** into between panel **(3)**, **(4)** and **(5)**.
(Repeat 4 times.)

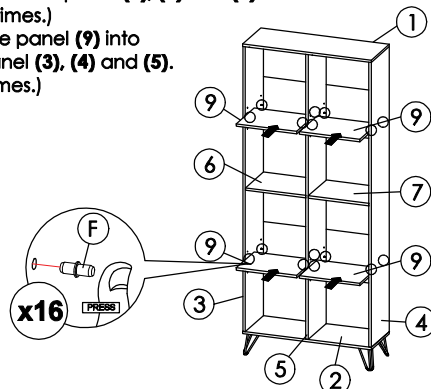

*Hardware **F** can fix to another up and down hole on panel **(3)**, **(4)** and **(5)** for adjust the panel **(9)** to high or lower.

CODING
- 522044



ISO 9001:2015
Reg. No. 00035-1-MY-1-QMS

nuhoom.com

STEP 13

Assemble hardware **11** into panel **(1)** and **(8)** by using hardware **12**.
(Repeat 2 times.)

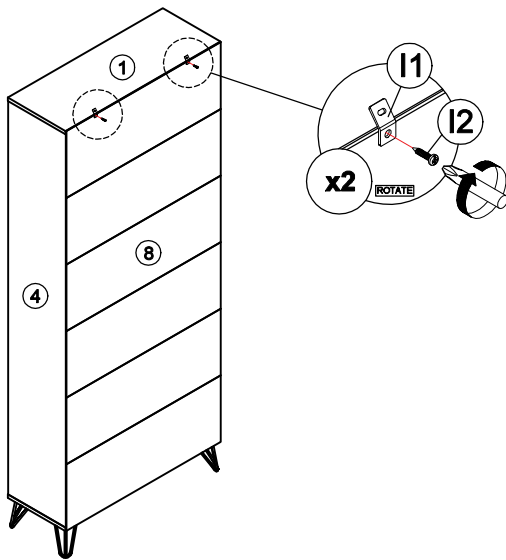

STEP 14

- Mark and use the power drill to drill a hole on the wall.
- Hit hardware **13** into the wall.
(Repeat 2 times.)

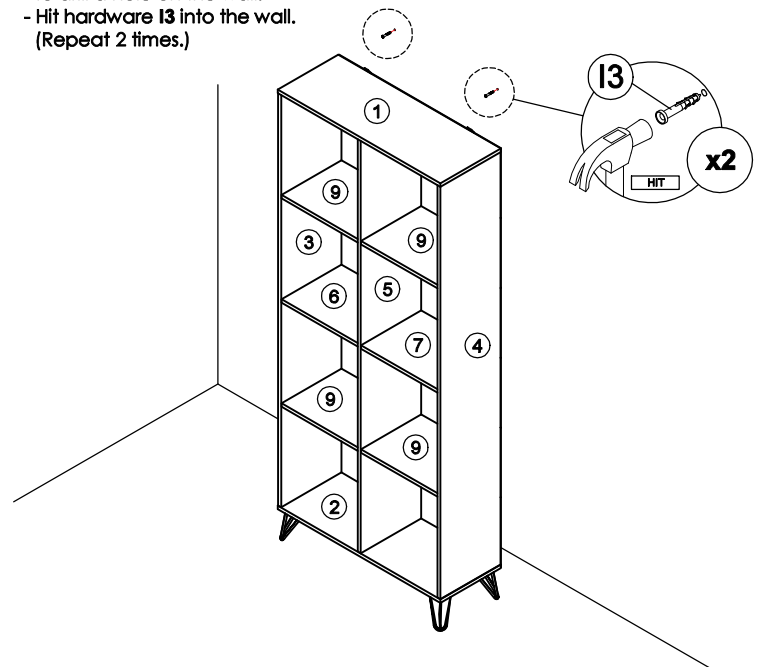

STEP 15

- Assemble hardware **11** to **13** by using hardware **14**.
(Repeat 2 times.)

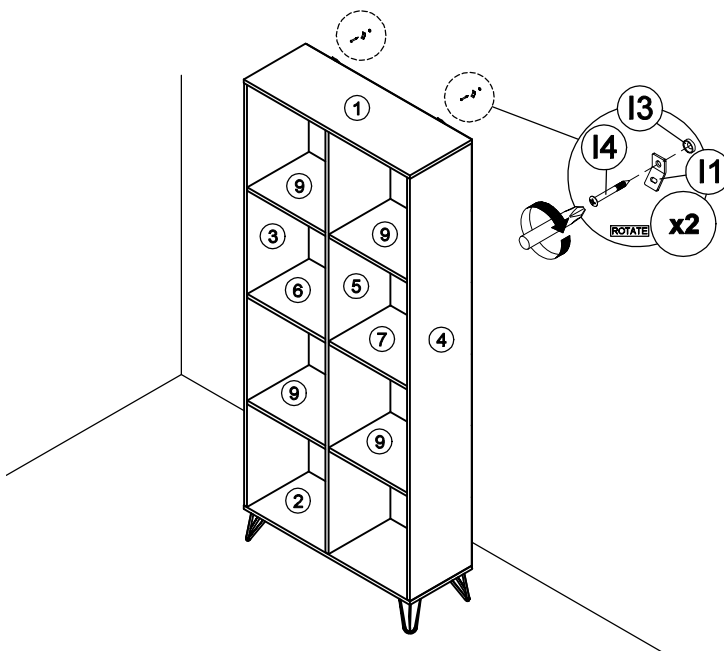

STEP 16

- Connect both of the hardware **11** by using hardware **15**.
- Tighten the hardware **15**.
(Repeat 2 times.)

