

CODING
- 372067

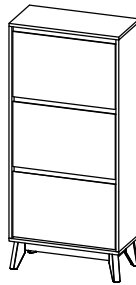

ISO 9001:2015
Reg. No. 07035-1-MY-1-QMS

nuhoom.com

Read the instructions carefully. Remove all the wrappings, staples and straps from the carton. Refer to the hardware and furniture part list for guidance. Make sure that you have all the parts before you start assembling. Place all the wooden furniture parts on a clean, flat and soft surface, such as a carpet or rubbermat to prevent scratches.

CAUTION
KEEP ALL THE PARTS OUT OF CHILDREN'S REACH.

PART LIST		QTY
1	TOP PANEL	1 PC
2	BOTTOM PANEL	1 PC
3	SIDE PANEL (L)	1 PC
4	SIDE PANEL (R)	1 PC
5	BONE PANEL	1 PC
6	BACK SUPPORT	1 PC
7	BACK PANEL	1 PC
8	DOOR PANEL (UP)	2 PCS
9	DOOR PANEL (DOWN)	1 PC
10	DOOR BONE	2 PCS
11	MIDDLE PANEL	6 PCS
12	MIDDLE BOTTOM	3 PCS
13	CABINET LEG	4 PCS

HARDWARE			
A	MINI FIX	A1 A2 A3	8 SETS
B	M8 X 30MM WOOD DOWEL		12 PCS
C	M8 X 25MM WOOD DOWEL		4 PCS
D	M6 X 50MM CSK CAP WOOD SCREW		4 PCS
E	ALLEN KEY M4		1 PC
F	M3 X 12MM C.B SCREW		18 PCS
G	M3.5 X 16MM C.B SCREW		18 PCS
H	M4 X 20MM C.B SCREW		12 PCS
I	5/8 NAIL		24 PCS
J	JCBC SCREW M6 X 70MM		8 PCS
K	SPRING WASHER M6		8 PCS
L	FLAT WASHER M6		8 PCS
M	STOPPER(2 PIN)		6 PCS
N	2 TRAY SHOE RACK 195MM	N1 N2 N3	3 SETS
O	TIPPING PACK WITHOUT AI	O1 O2 O3 O4 O5	2 SETS

SELF-PREPARED TOOLS: Tools below are NOT included in package.	
SCREWDRIVER	HAMMER

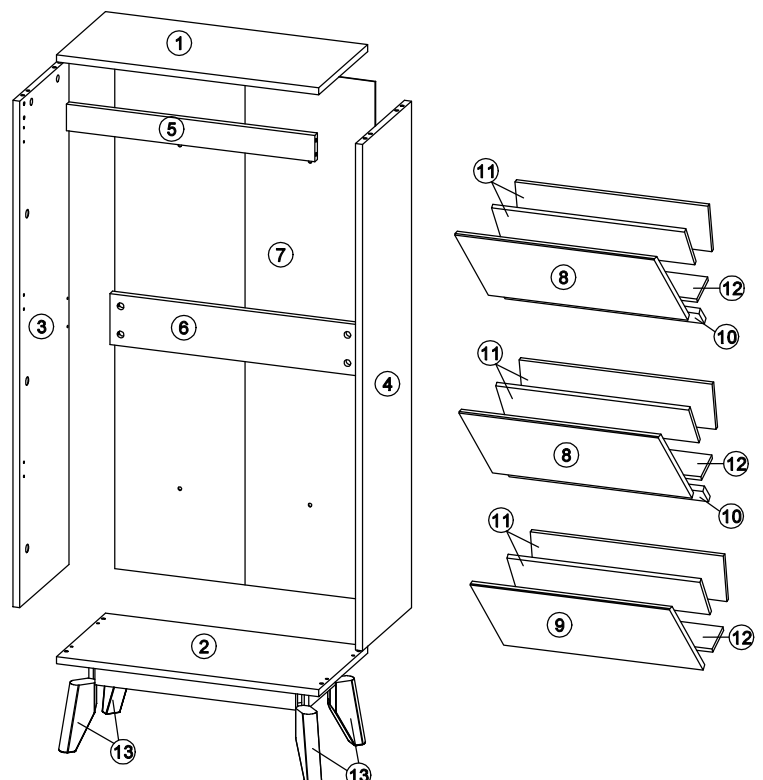

CODING
- 372067

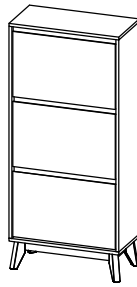

ISO 9001:2015
Reg. No. 070435-1-MY-1-QMS

nuhoom.com

STEP 1

- Insert hardware **A1** onto panel (3), (4) and (6). (Repeat 8 times.)
- Insert hardware **A2** onto panel (1), (3) and (4). (Repeat 8 times.)
- Insert hardware **B** onto panel (3), (4) and (5). (Repeat 12 times.)

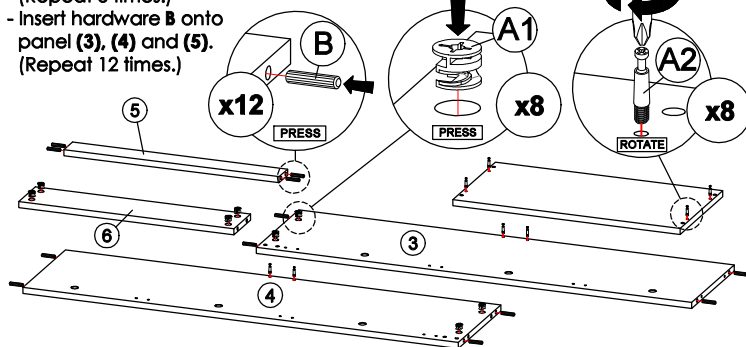

STEP 2

- Hit hardware **M** onto panel (3) and (4). (Repeat 6 times.)

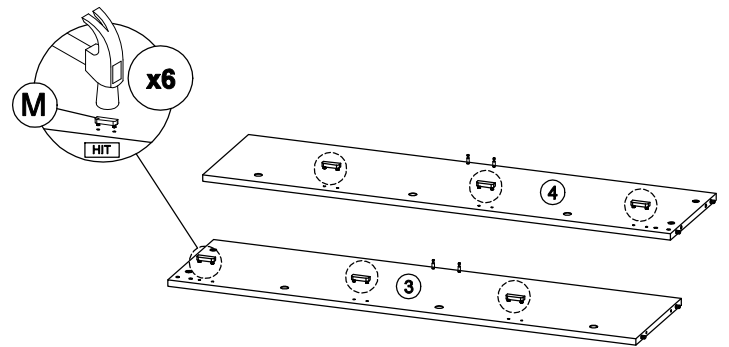

* Ensure the arrows on hardware **A1** point towards mounting positions.

* In this step hardware **A1**, **A2** and **B** are pre-inserted.

STEP 3

- Attach panel (3) and (4) to panel (5) and (6).
- Insert all hardware **A2** into **A1**.
- Rotate all **A1** until tight.
- Apply **A3** onto all **A1**. (Repeat 4 times.)



OR

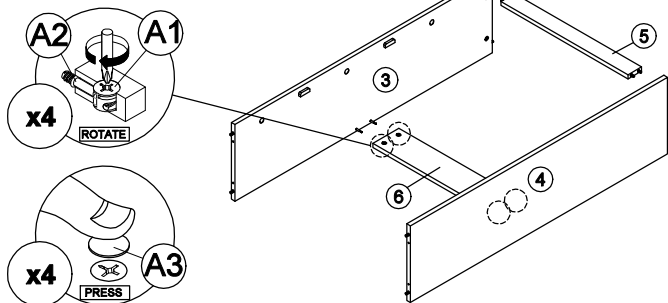

* In this step hardware **A1**, **A2** and **B** are pre-inserted.

STEP 4

- Attach panel (1) to panel (3) and (4).
- Insert all hardware **A2** into **A1**.
- Rotate all **A1** until tight.
- Apply **A3** onto all **A1**. (Repeat 4 times.)



OR

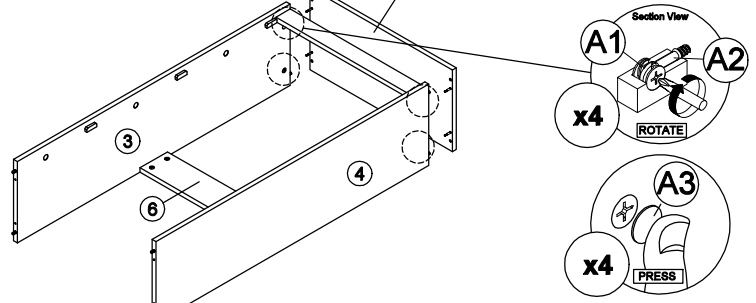

* In this step hardware **A1**, **A2** and **B** are pre-inserted.

STEP 5

- Connect panel (2) to panel (3) and (4) by using hardware **D** and **E**. (Repeat 4 times.)

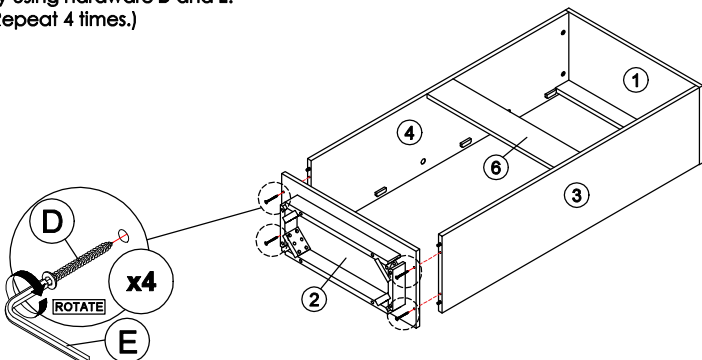

* In this step hardware **B** are pre-inserted.

STEP 6

- Assemble part **13** into panel (2) by using hardware **E**, **J**, **K** and **L**. (Repeat 2 times for each Leg.)

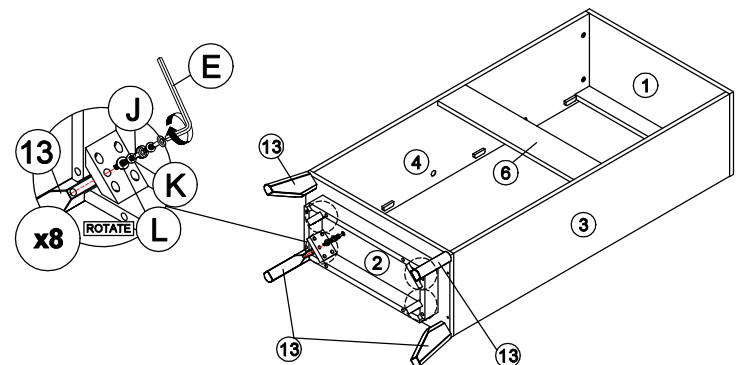

CODING
- 372067

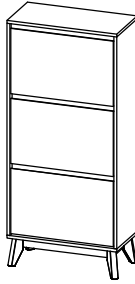

ISO 9001:2015
Reg. No. 000435-1-MY-1-QMS

nuhoom.com

STEP 7
Assemble panel (7) to entire body with hardware I.
(Repeat 24 times.)

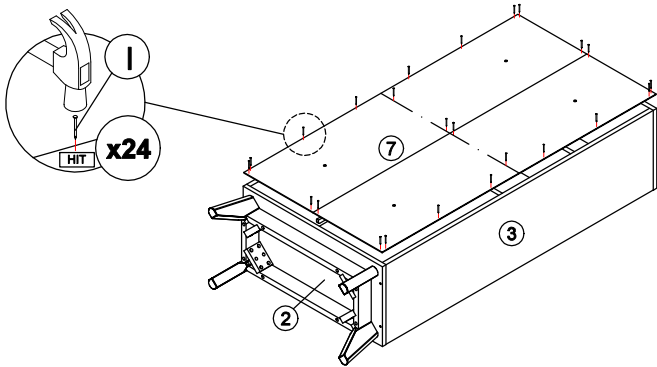

STEP 8
Fix hardware N1 (L/R) onto panel (11) by using hardware F.
(Repeat 1 times for each hardware.)

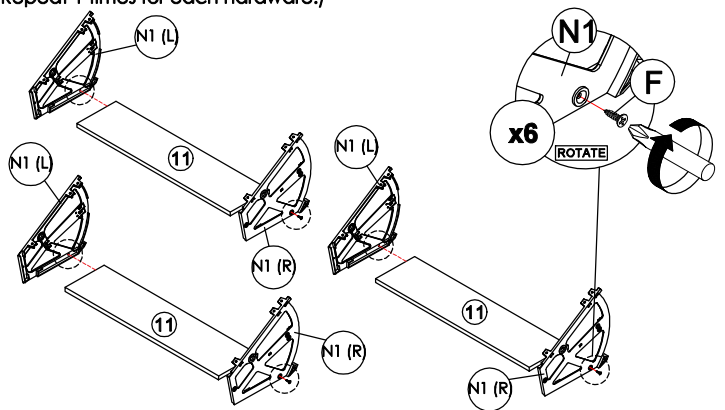

STEP 9
- Insert the panel (12) along the slot.
(Repeat 3 times.)
- Fix hardware N1 (L/R) onto panel (12) by using hardware F.
(Repeat 1 times for each hardware.)

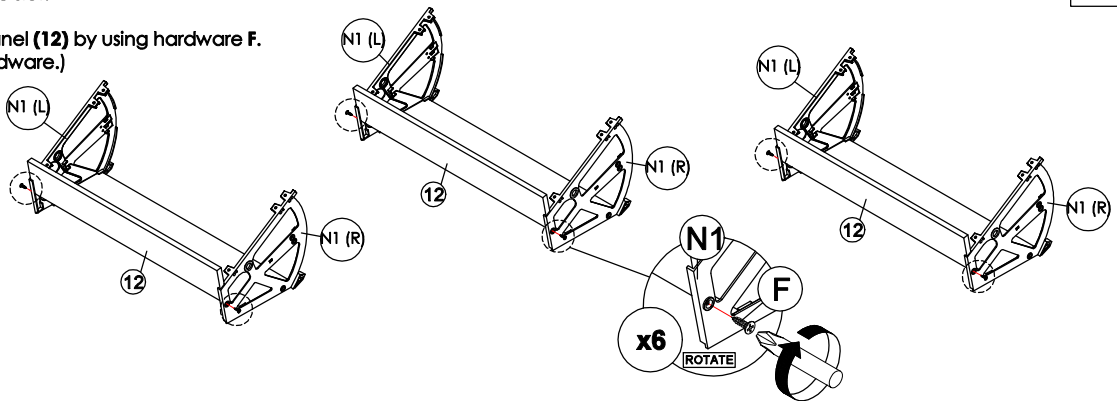

STEP 10
Insert hardware C onto panel (8).
(Repeat 4 times.)

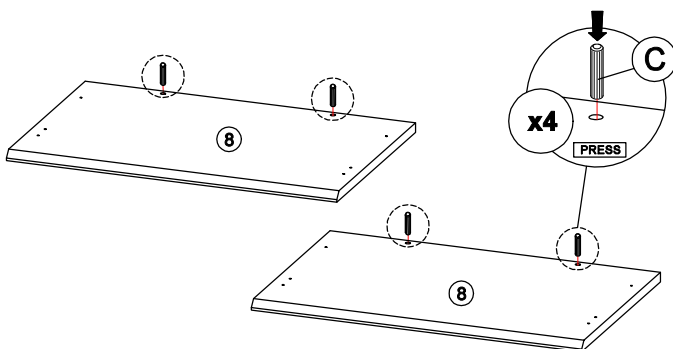

STEP 11
Assemble panel (10) with panel (8)
by using hardware H.
(Repeat 6 times.)

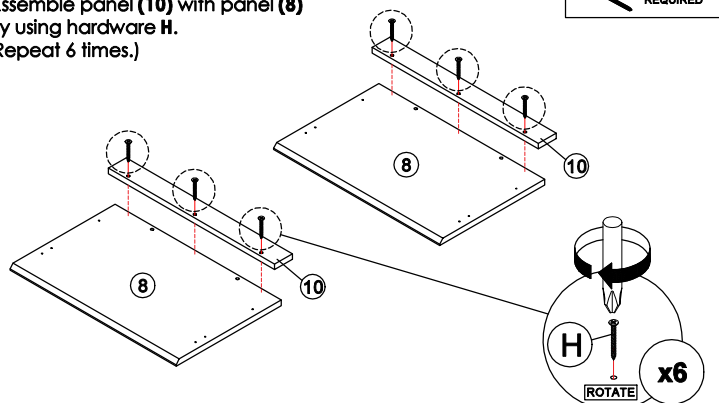

CODING
- 372067

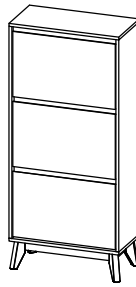

ISO 9001:2015
Reg. No. 000435-1-MY-1-QMS

nuhoom.com

STEP 12
Fix hardware **N1 (L/R)** onto panel **(8)** by using hardware **G**.
(Repeat 3 times for each hardware.)



STEP 13
Fix hardware **N1 (L/R)** onto panel **(9)** by using hardware **G**.
(Repeat 3 times for each hardware.)

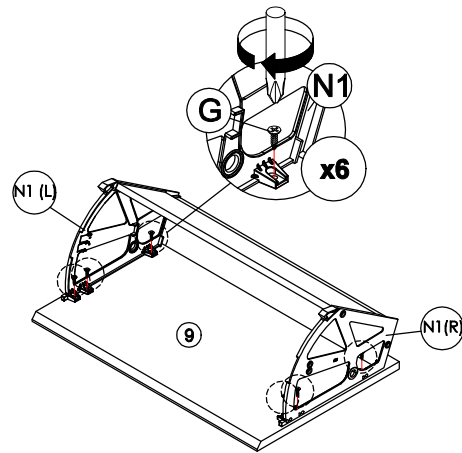
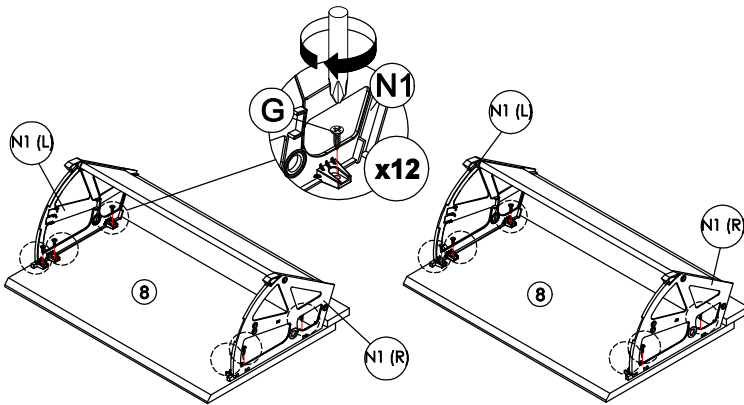

STEP 14
Assemble hardware **N1 (L/R)** into panel **(3)** and **(4)**
by using hardware **H**, **N2** and **N3**.
(Repeat 1 times for each hardware .)



STEP 15
- Insert the panel **(11)** along the slot.
(Repeat 2 times.)
- Fix hardware **N1 (L/R)** onto panel **(11)** by using hardware **F**.
(Repeat 1 times for each hardware.)

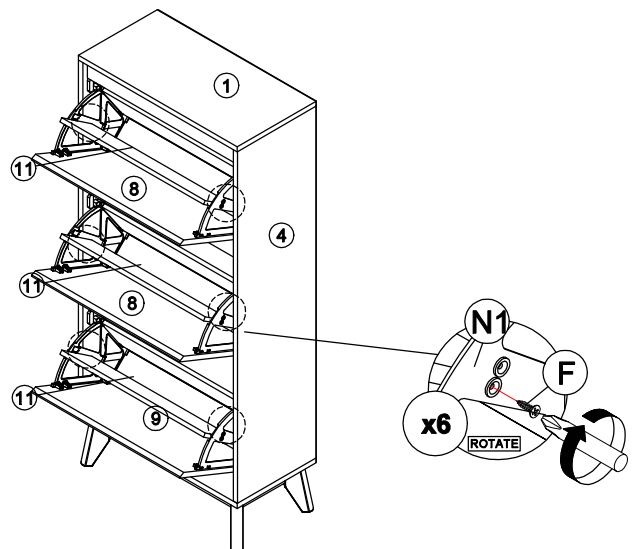
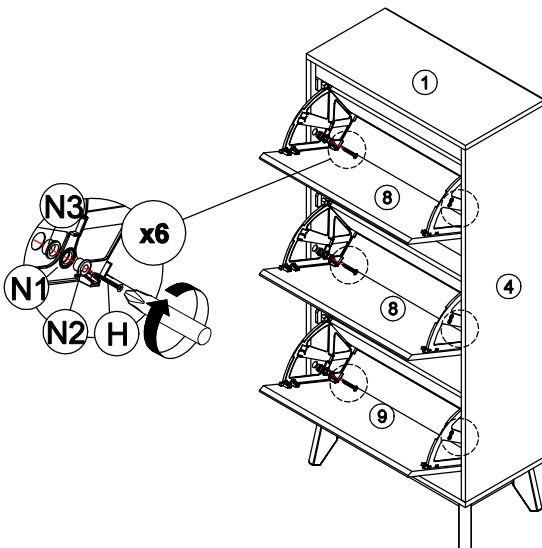

CODING
- 372067

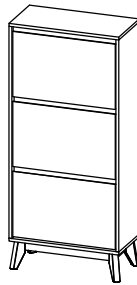

ISO 9001:2015
Reg. No. 000435-1-MY-1-QMS

nuhoom.com

STEP 16

Assemble hardware **O1** into panel **(1)** and **(7)** by using hardware **O2**.
(Repeat **2** times.)

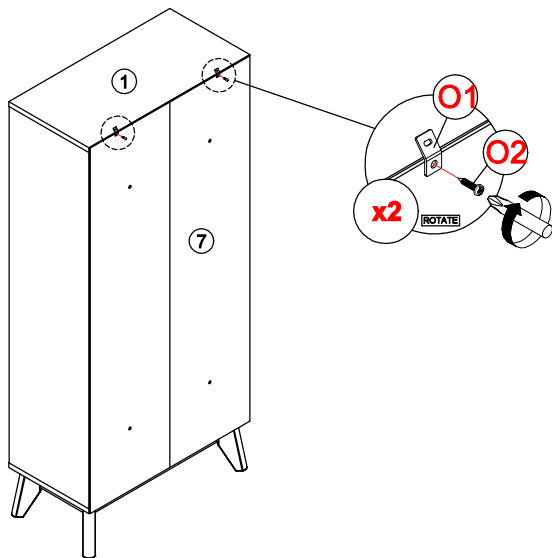

STEP 17

- Mark and use the power drill to drill a hole on the wall.
- Hit hardware **O3** into the wall.
(Repeat **2** times.)

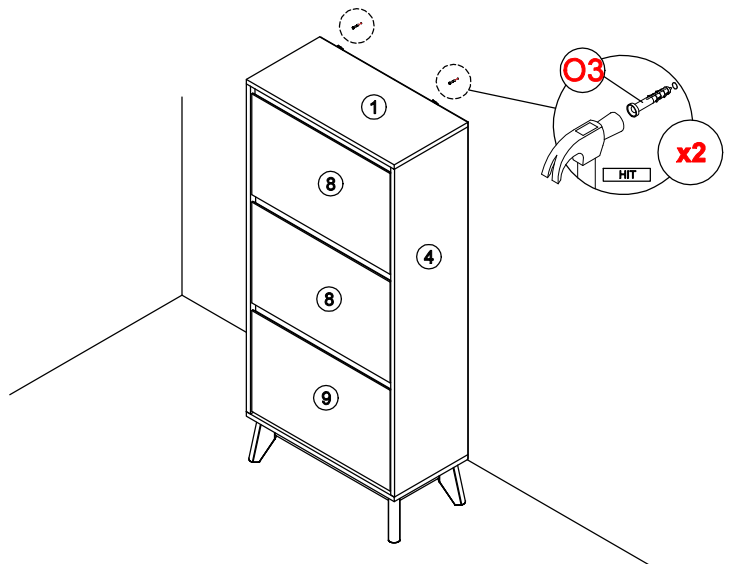

STEP 18

Assemble hardware **O1** to **O3** by using hardware **O4**.
(Repeat **2** times.)

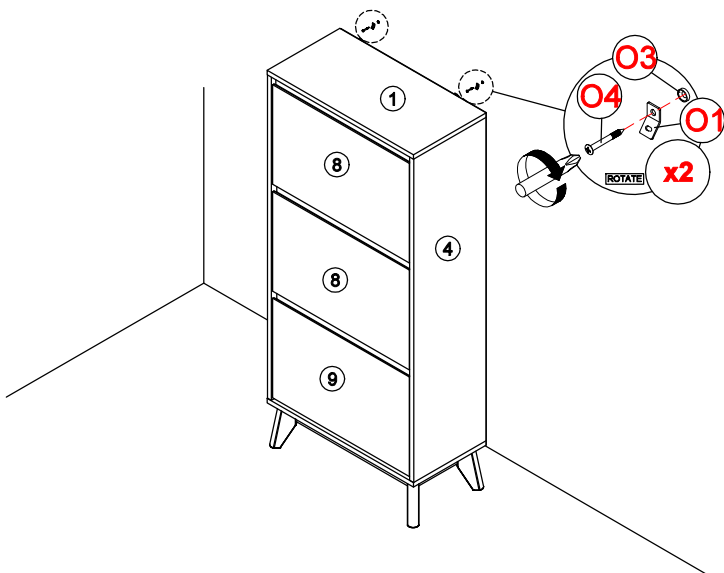

STEP 19

- Connect both of the hardware **O1** by using hardware **O5**.
- Tighten the hardware **O5**.
(Repeat **2** times.)

