

CODING
- 372066

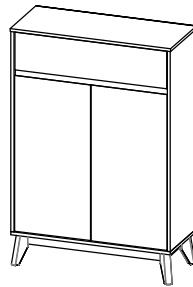

ISO 9001:2015
Reg. No. 000435-1-MY-1-QMS

nuhoom.com

Read the instructions carefully. Remove all the wrappings, staples and straps from the carton. Refer to the hardware and furniture part list for guidance. Make sure that you have all the parts before you start assembling. Place all the wooden furniture parts on a clean, flat and soft surface, such as a carpet or rubbermat to prevent scratches.

CAUTION
KEEP ALL THE PARTS OUT OF CHILDREN'S REACH.

PART LIST		QTY
1	TOP PANEL	1 PC
2	BOTTOM PANEL	1 PC
3	SIDE PANEL (L)	1 PC
4	SIDE PANEL (R)	1 PC
5	BONE PANEL	1 PC
6	SHELF PANEL	3 PCS
7	BACK PANEL	1 PC
8	DOOR PANEL (L)	1 PC
9	DOOR PANEL (R)	1 PC
10	DRAWER FRONT	1 PC
11	DRAWER SIDE	2 PCS
12	DRAWER BACK	1 PC
13	DRAWER BOTTOM	1 PC
14	LEG	4 PCS

HARDWARE			
A	MINI FIX	A1 A2 A3	4 PCS
B	M8 X 30MM WOOD DOWEL		12 PCS
C	M6 X 50MM CSK CAP WOOD SCREW		4 PCS
D	5/8 NAIL		30 PCS
E	ALLEN KEY M4		1 PC
F	ONE HOLE L BRACKET (2MM)		2 PCS
G	M3.5 X 16MM C.B SCREW		42 PCS
H	M4 X 38MM C.B SCREW		8 PCS
I	METAL SHELF SUPPORT		12 PCS
J	STOPPER(2 PIN)		1 PC
K	12" DRAWER SLIDE	K1 (L/R) K2 (L/R)	1 SET
L	SOFT CLOSING 7/8 HINGES		4 PCS
M	JCBC Screw M6 x 70		8 PCS
N	SPRING WASHER M6		8 PCS
O	FLAT WASHER M6		8 PCS
P	TIPPING PACK	P1 P2 P3 P4 P5	2 SETS

SELF-PREPARED TOOLS: Tools below are NOT included in package.	
SCREWDRIVER	HAMMER

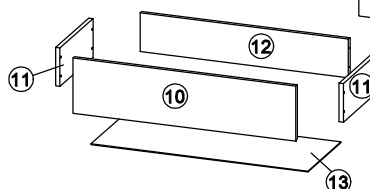
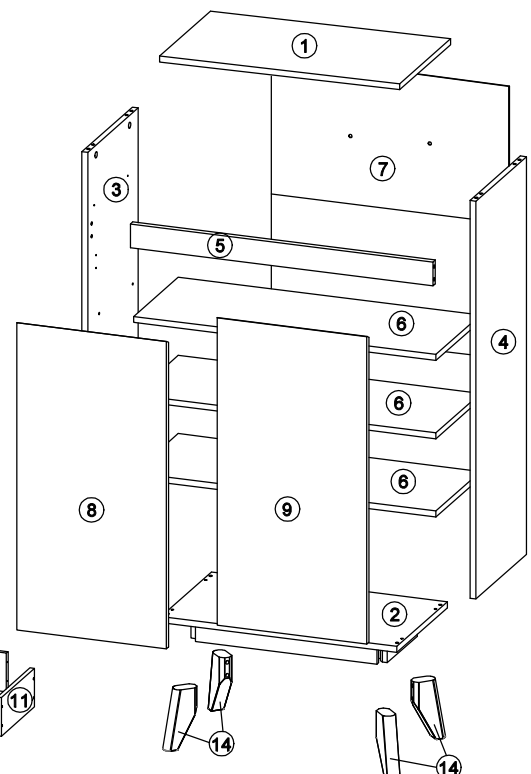

CODING
- 372066

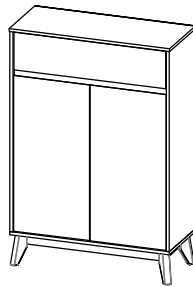

ISO 9001:2015
Reg. No. 000435-1-MY-1-QMS

nuhoom.com

STEP 1

- Insert hardware **A2** onto panel (1).
(Repeat 4 times.)
- Hit hardware **J** onto panel (2).
(Repeat 1 times.)

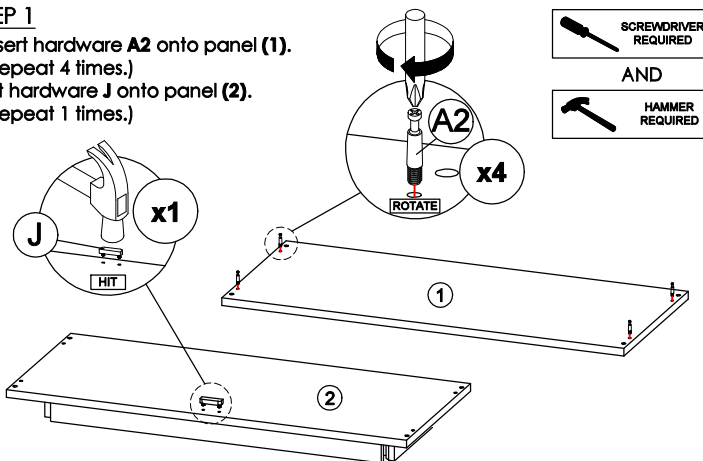

SCREWDRIVER
REQUIRED

AND

HAMMER
REQUIRED

STEP 2

- Insert hardware **A1** onto panel (3) and (4).
(Repeat 2 times on each panel.)
- Insert hardware **B** onto panel (3) and (4).
(Repeat 4 times on each panel.)
- Assemble hardware **F** to panel (5) with hardware **G**.
(Repeat 2 times on each panel.)
- Insert hardware **B** onto panel (5).
(Repeat 4 times on each panel.)

SCREWDRIVER
REQUIRED

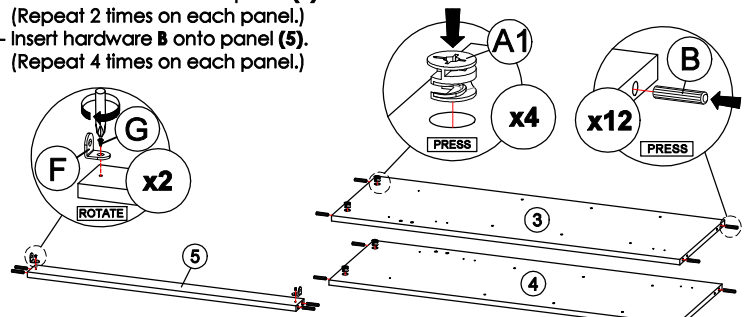

* Ensure the arrows on hardware **A1** point towards mounting positions.

STEP 3

- Fix hardware **K1 (L)** into panel (3) with hardware **G**.
(Repeat 4 times for each hardware.)
- Fix hardware **K1 (R)** into panel (4) with hardware **G**.
(Repeat 4 times for each hardware.)

SCREWDRIVER
REQUIRED

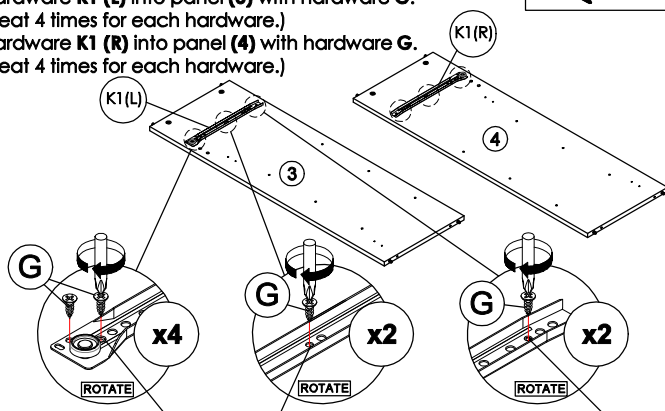

STEP 4

- Attach panel (5) to panel (3) and (4).
(Repeat 1 times.)

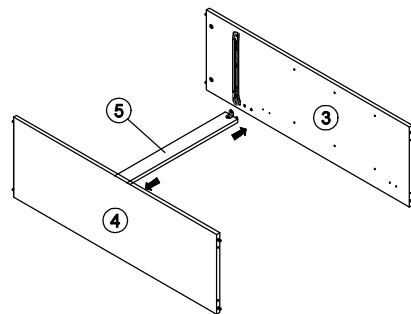

First and top second from the edge. Small hole at the center. Third hole from the edge.

* In this step hardware **B** are pre-inserted.

STEP 5

- Attach panel (3) and (4) to panel (1).
- Insert all hardware **A2** into **A1**.
- Rotate all **A1** until tight.
- Apply **A3** onto all **A1**.
(Repeat 4 times.)

SCREWDRIVER
REQUIRED

OR

HARDWARE
E

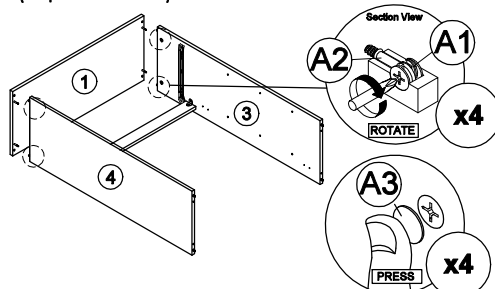

* In this step hardware **A1**, **A2** and **B** are pre-inserted.

STEP 6

- Connect panel (2) to panel (3) and (4) by using hardware **C** and **E**.
(Repeat 4 times.)

HARDWARE
E

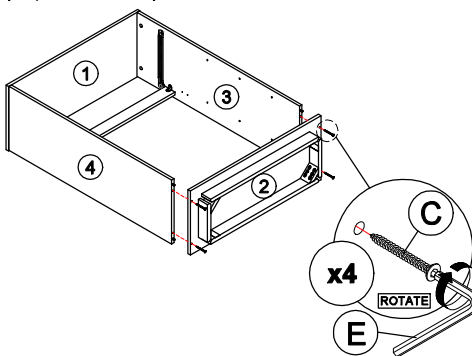

* In this step hardware **B** are pre-inserted.

STEP 7

- Assemble hardware **F** on panel (5) to panel (3) and (4) by using hardware **G**.
(Repeat 1 times on each side panel.)

SCREWDRIVER
REQUIRED

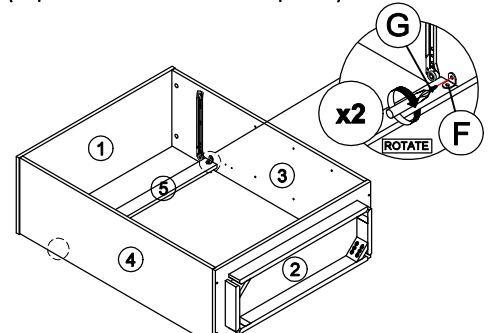

CODING
- 372066

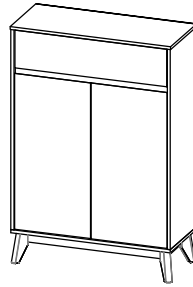

ISO 9001:2015
Reg. No. 000436-1-MY-1-QMS

nuhoom.com

STEP 8
Assemble part **14** into panel **(2)** by using hardware **E, M, N** and **O**.
(Repeat 2 times for each Leg.)



STEP 9
Assemble panel **(7)** to entire body with hardware **D**.
(Repeat 18 times.)

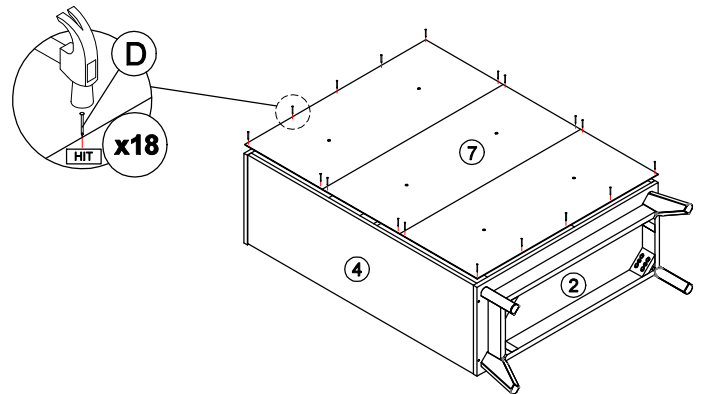
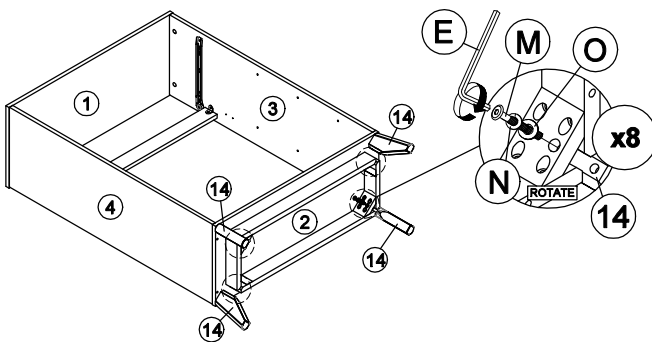

STEP 10
Insert hardware **I** into mounting positions on panel **(3)** and **(4)** by hand.
(Repeat 12 times.)

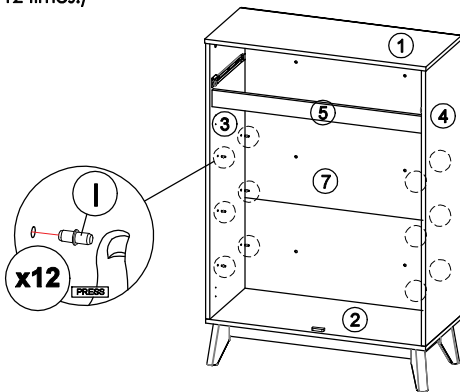

STEP 11
Assemble the panel **(6)** into between panel **(3)** and **(4)**.
(Repeat 3 times.)

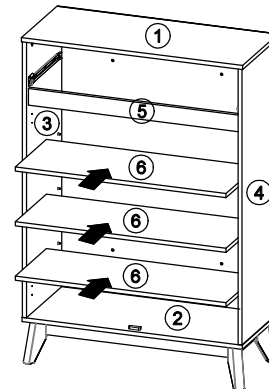

STEP 12
Fix hardware **L** onto panel **(8)** and **(9)** by using hardware **G**.
(Repeat 2 times for each hardware.)



STEP 13
- Fix hardware **L** into panel **(3)** and **(4)** by using hardware **G**.
(Repeat 4 times for each hardware.)
- Tighten or loosen the screw to adjust position of panel **(8)** and **(9)**.
(Do only when needed.)

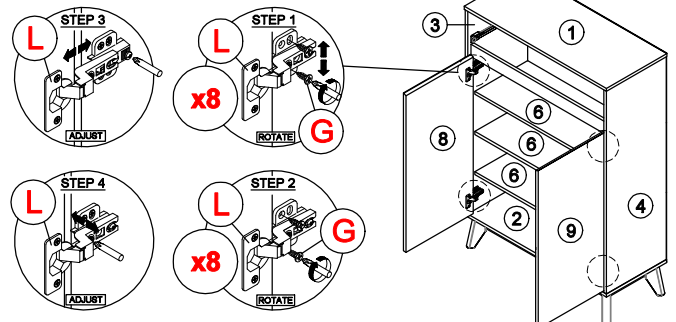
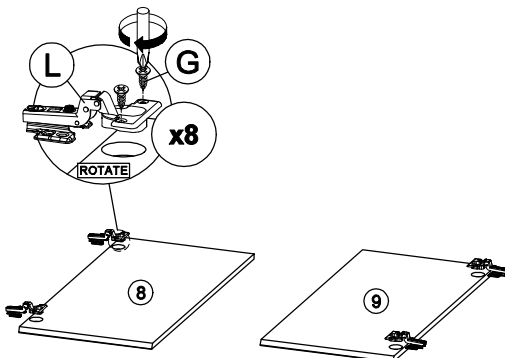

* In this step hardware **L** have been assembled in panel **(8)** and **(9)**.

CODING
- 372066

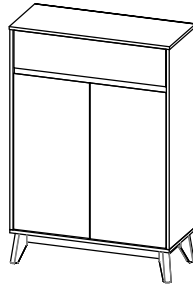

ISO 9001:2015
Reg. No. 000435-1-MY-1-QMS

nuhoom.com

STEP 14

Assemble panel (11) with panel (10) and (12) by using hardware H. (Repeat 8 times for each drawer.)



STEP 15

Assemble panel (13) to entire body with hardware D. (Repeat 12 times.)

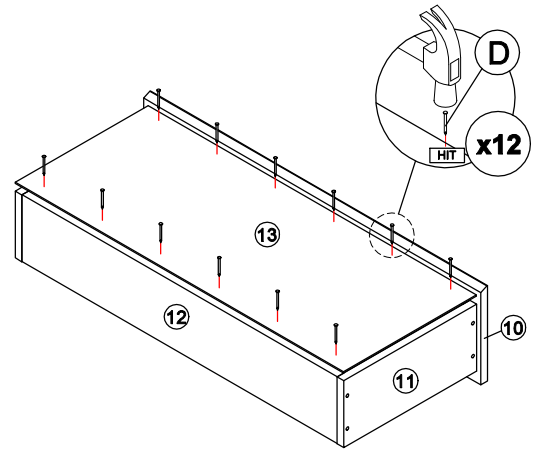
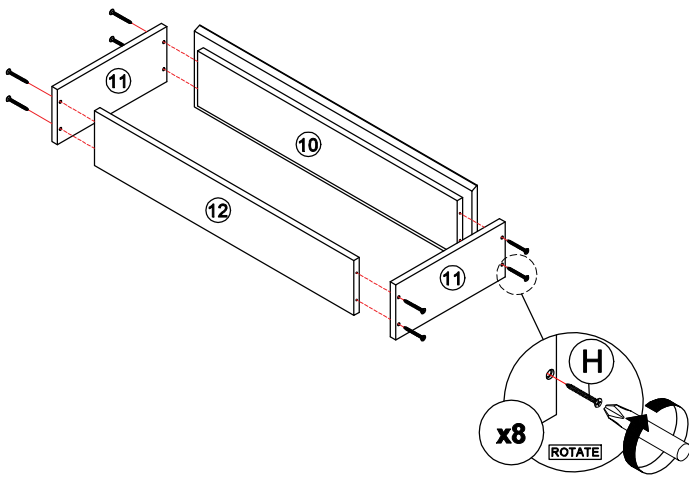

STEP 16

Assemble hardware K2 (L/R) to panel (13) by using hardware G. (Repeat 3 times for each hardware.)



STEP 17

Put all the drawer in place along the drawer slides.

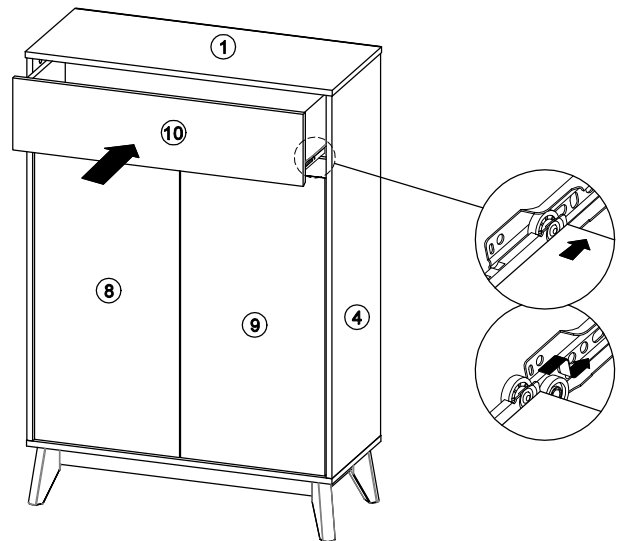
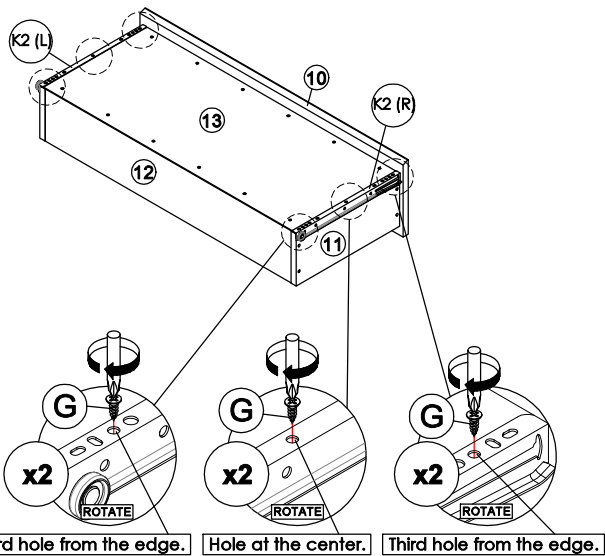

*Hardware K2 (L/R) shall be leaning against panel (10) when assembling.

CODING
- 372066

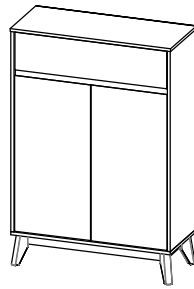

ISO 9001:2015
Reg. No. 000435-1-MY-1-QMS

nuhoom.com

STEP 18
Assemble hardware **P1** into panel **(1)** and **(7)** by using hardware **P2**.
(Repeat **2** times.)

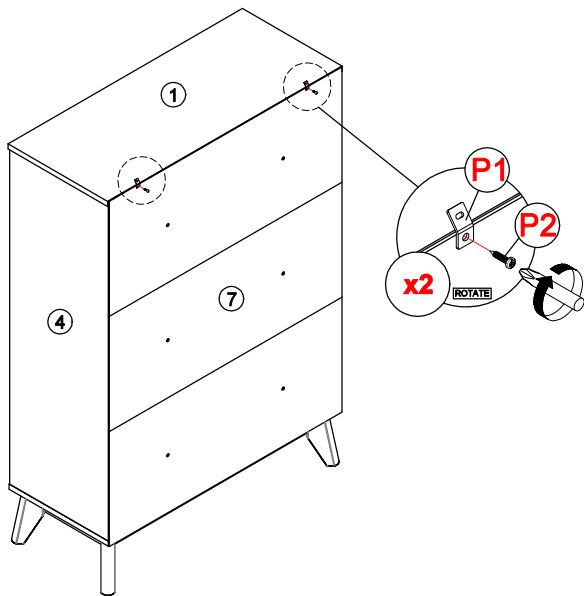

STEP 19
- Mark and use the power drill to drill a hole on the wall.
- Hit hardware **P3** into the wall.
(Repeat **2** times.)

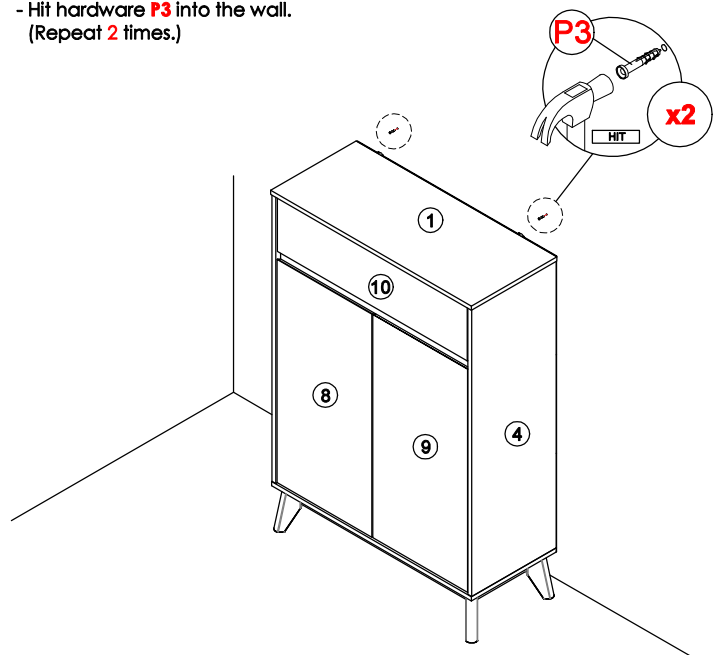

STEP 20
Assemble hardware **P1** to **P3** by using hardware **P4**.
(Repeat **2** times.)

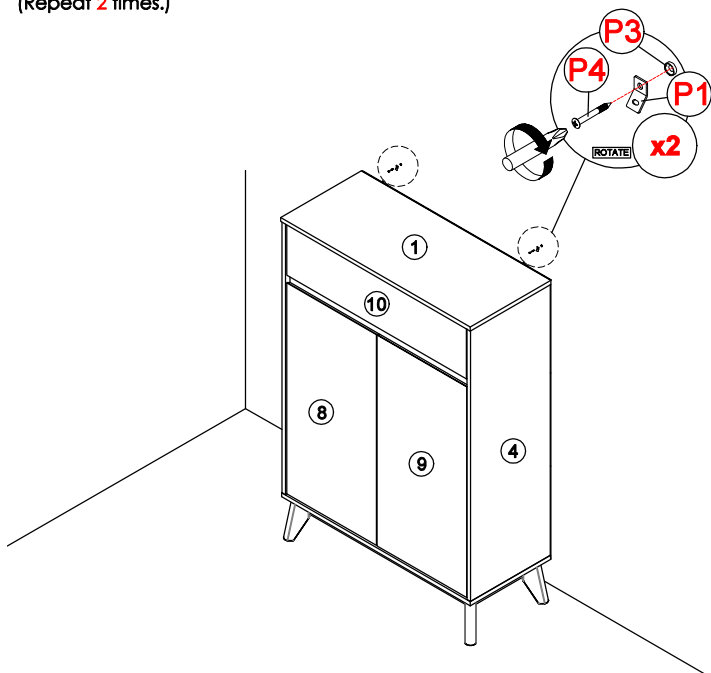

STEP 21
- Connect both of the hardware **P1** by using hardware **P5**.
- Tighten the hardware **P5**.
(Repeat **2** times.)

