

CODING

- 353011
- 353008
- 353014

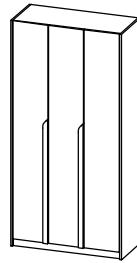

ISO 9001:2015
Reg. No. 09455-1-MY-1-QMS

nuhoom.com

Read the instructions carefully. Remove all the wrappings, staples and straps from the carton. Refer to the hardware and furniture part list for guidance. Make sure that you have all the parts before you start assembling. Place all the wooden furniture parts on a clean, flat and soft surface, such as a carpet or rubbermat to prevent scratches.

CAUTION
KEEP ALL THE PARTS OUT OF CHILDREN'S REACH.

PART LIST		QTY
1	TOP PANEL	1 PC
2	BOTTOM PANEL	1 PC
3	SIDE PANEL (L)	1 PC
4	SIDE PANEL (R)	1 PC
5	CENTER PANEL	1 PC
6	MIDDLE PANEL (L)	1 PC
7	MIDDLE PANEL (R)	1 PC
8	BACK PANEL	1 PC
9	SHELF PANEL	2 PCS
10	DOOR PANEL (L)	2 PCS
11	DOOR PANEL (R)	1 PC
12	LEG PANEL	2 PCS
13	CENTER LEG PANEL	1 PC
14	HANDLE	2 PCS

HARDWARE

A	MINI FIX	A1 A2 A3	25 SETS
B	M8 X 30MM WOOD DOWEL		26 PCS
C	M6 X 50MM CSK CAP WOOD SCREW		2 PCS
D	ALLEN KEY M4		1 PC
E	M3.5 X 16MM C.B SCREW		58 PCS
F	M4 X 25MM C.B SCREW		8 PCS
G	5/8 NAIL		42 PCS
H	5/8 PVC NAIL LEG		10 PCS
I	METAL SHELF SUPPORT		8 PCS
J	SOFT CLOSING 7/8 HINGES		9 PCS
K	433 OVAL TUBE BRACKET		2 PCS
L	433 OVAL PAIP		1 PC

SELF-PREPARED TOOLS: Tools below are NOT included in package.

	SCREWDRIVER		HAMMER
--	-------------	--	--------

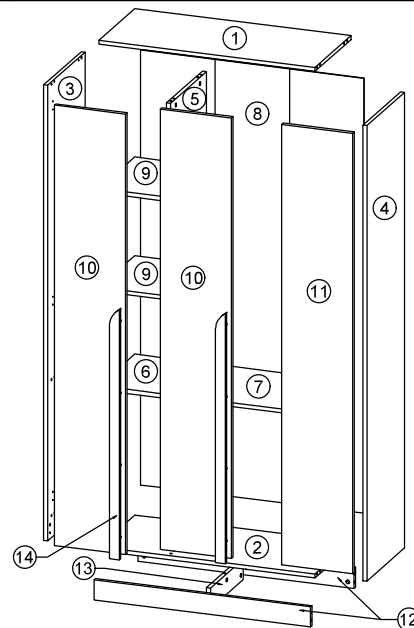

CODING
- 353008

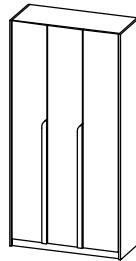

ISO 9001:2015
Reg. No. 09045-1-MY-1-QMS

nuhoom.com

STEP 1

- Insert hardware **A1** onto panel **(1)**, **(2)**, **(5)** and **(12)**. (Repeat 14 times.)
- Insert hardware **A2** onto panel **(1)**, **(2)**, **(5)** and **(12)**. (Repeat 9 times.)
- Insert hardware **B** onto panel **(1)**, **(2)**, **(5)** and **(12)**. (Repeat 16 times.)

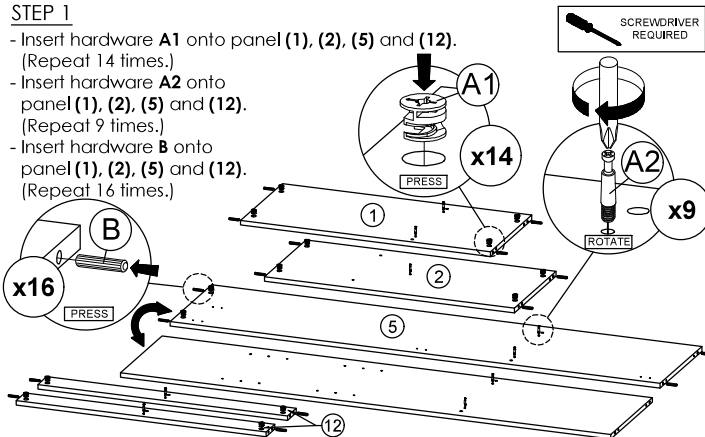

* Ensure the arrows on hardware **A1** point towards mounting positions.

STEP 3

- Assemble the hardware **K** onto panel **(4)** and **(5)** by using hardware **E**. (Repeat 2 times for each hardware.)

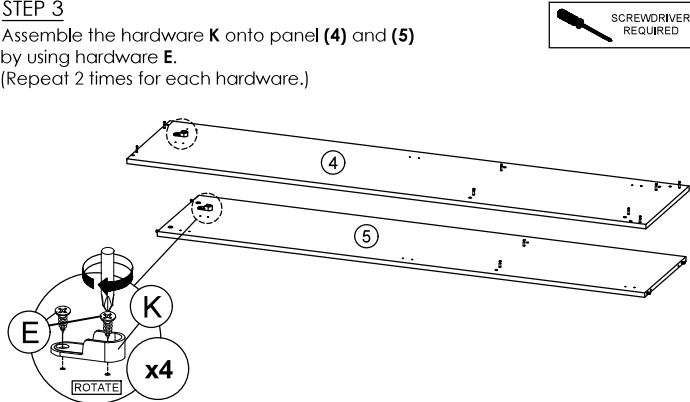

* In this step hardware **A1**, **A2** and **B** are pre-inserted.

STEP 5

- Attach panel **(1)** to panel **(5)**.
- Insert all hardware **A2** into **A1**.
- Rotate all **A1** until tight.
- Apply **A3** onto all **A1**. (Repeat 2 times.)

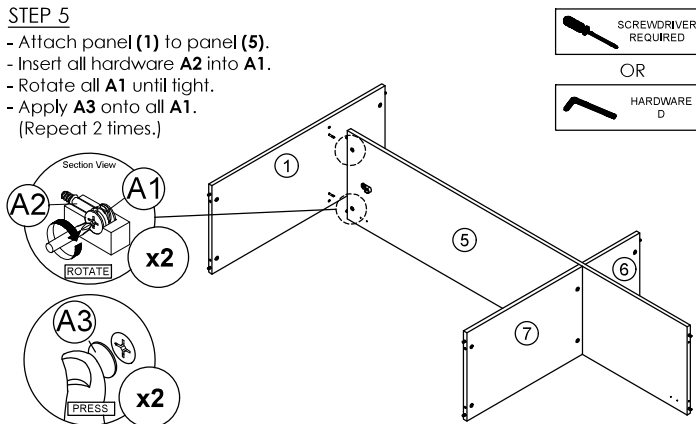

* In this step hardware **A1**, **A2** and **B** are pre-inserted.

STEP 2

- Insert hardware **A1** onto panel **(6)**, **(7)** and **(13)**. (Repeat 11 times.)
- Insert hardware **A2** onto panel **(3)** and **(4)**. (Repeat 16 times.)
- Insert hardware **B** onto panel **(6)**, **(7)** and **(13)**. (Repeat 10 times.)

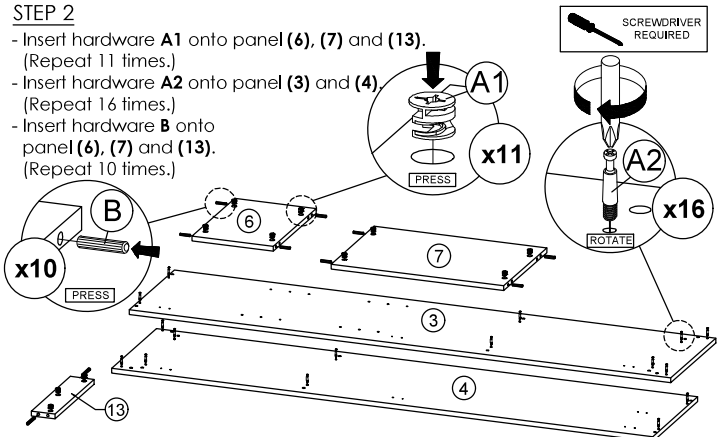

* Ensure the arrows on hardware **A1** point towards mounting positions.

STEP 4

- Attach panel **(5)** to panel **(6)** and **(7)**.
- Insert all hardware **A2** into **A1**.
- Rotate all **A1** until tight.
- Apply **A3** onto all **A1**. (Repeat 4 times.)

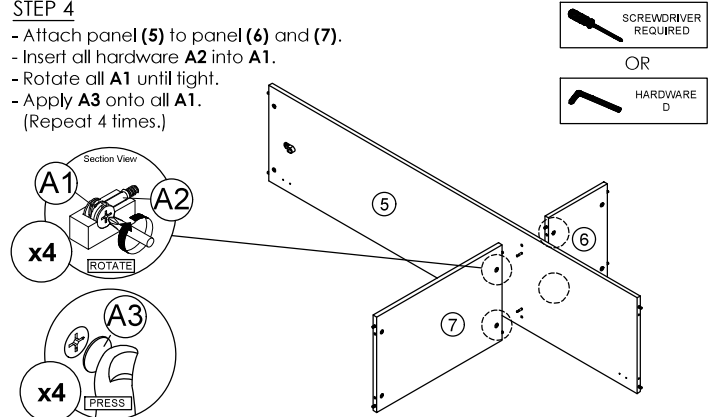

* In this step hardware **A1**, **A2** and **B** are pre-inserted.

STEP 6

- Connect panel **(2)** to panel **(5)** by using hardware **C** and **D**. (Repeat 2 times.)

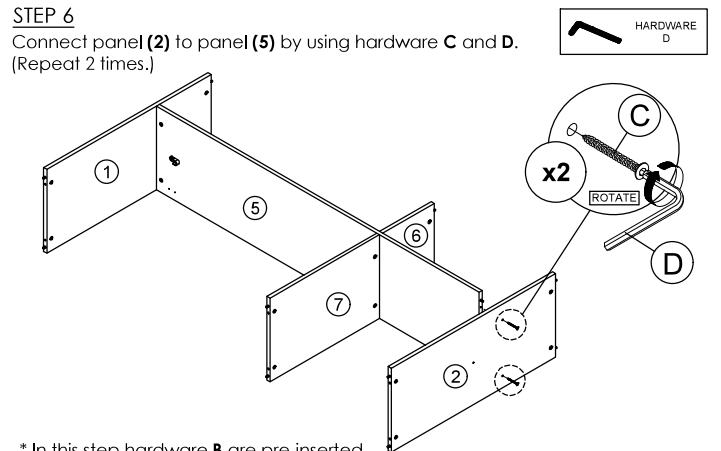

* In this step hardware **B** are pre-inserted.

CODING
- 353008

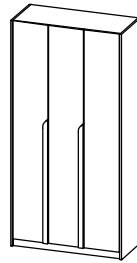

ISO 9001:2015
Reg. No. 09045-1-MY-1-QMS

nuhoom.com

STEP 7

- Attach panel (12) to panel (13).
- Insert all hardware A2 into A1.
- Rotate all A1 until tight.
- Apply A3 onto all A1.
- (Repeat 2 times.)

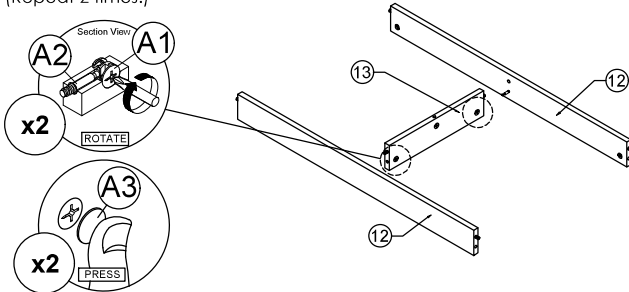
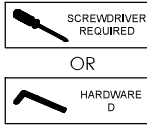

* In this step hardware A1, A2 and B are pre-inserted.

STEP 9

- Attach panel (3) and (4) to panel (1), (2), (6), (7) and (12).
- Insert all hardware A2 into A1.
- Rotate all A1 until tight.
- Apply A3 onto all A1.
- (Repeat 16 times.)

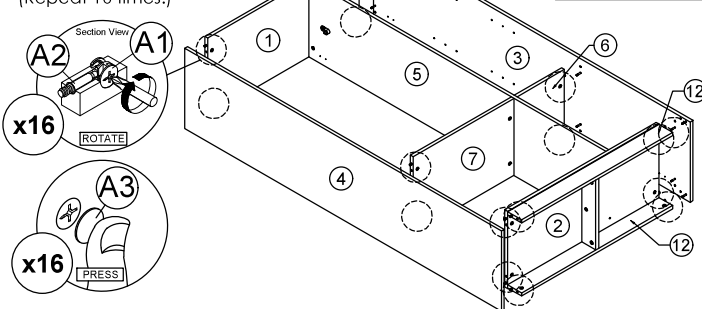
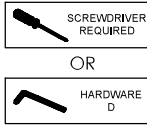

* In this step hardware A1, A2 and B are pre-inserted.

STEP 11

- Hit hardware H into bottom of panel (3), (4), (12) and (13).
- (Repeat 10 times.)

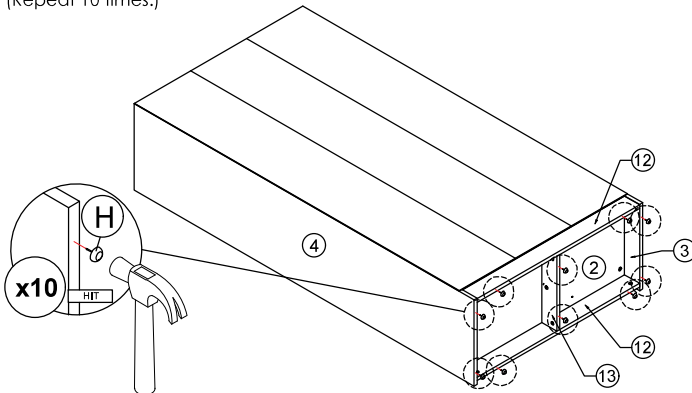

STEP 8

- Attach panel (13) to panel (2).
- Insert all hardware A2 into A1.
- Rotate all A1 until tight.
- Apply A3 onto all A1.
- (Repeat 1 times.)

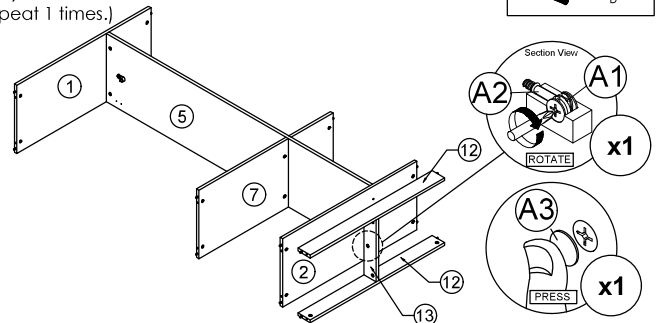
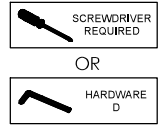

* In this step hardware A1, A2 and B are pre-inserted.

STEP 10

- Assemble panel (8) to entire body with hardware G.
- (Repeat 42 times.)

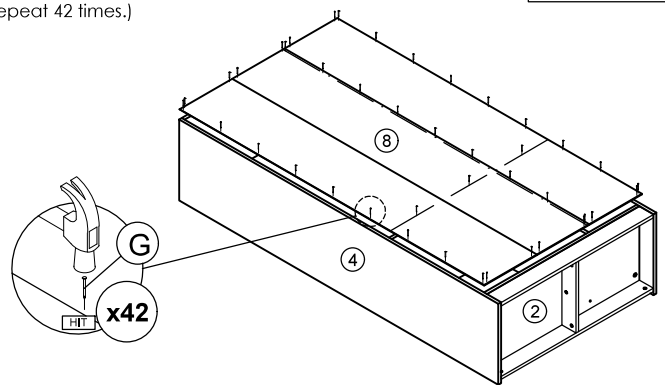

STEP 12

- Insert hardware I into mounting positions on panel (3) and (5) by hand.
- (Repeat 8 times.)

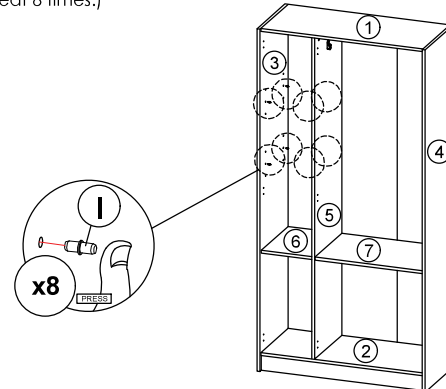

CODING
- 353008

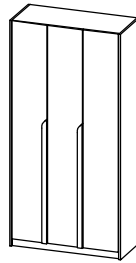

ISO 9001:2015
Reg. No. 100455-1-MY-1-QMS

nuhoom.com

STEP 13

Assemble the panel (9) into between panel (3) and (5).
(Repeat 2 times.)

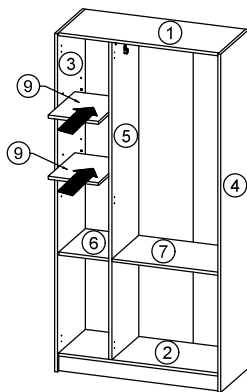

STEP 14

Attach hardware L to hardware K.
(Repeat 1 times.)

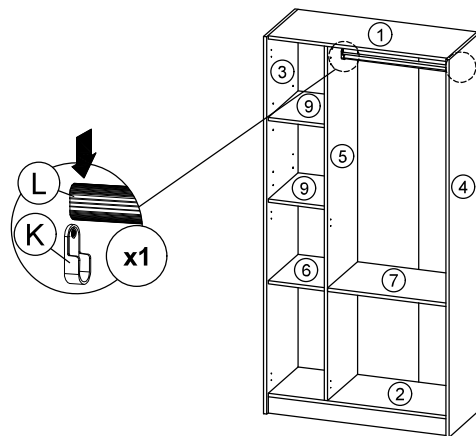

* In this step hardware I are pre-inserted.

STEP 15

- Fix hardware J onto panel (10) and (11) by using hardware E.
(Repeat 2 times for each hardware.)
- Assemble panel (14) to panel (10) with hardware F.
(Repeat 8 times.)

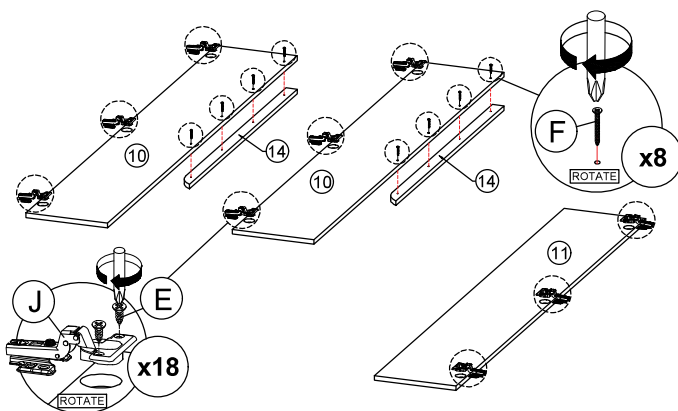

* In this step hardware K have been assembled.

STEP 16

- Fix hardware J into panel (3), (4) and (5) by using hardware E.
(Repeat 4 times for each hardware.)
- Tighten or loosen the screw to adjust position of panel (10) and (11).
(Do only when needed.)

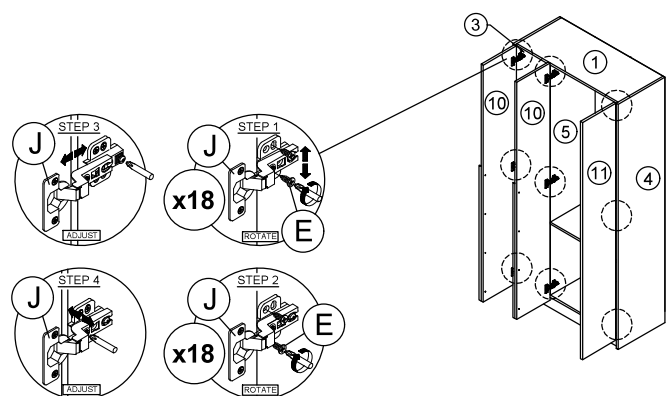

* In this step hardware J have been assembled in panel (10) and (11).