

**CODING**  
- 343043



ISO 9001:2015  
Reg. No. 070435-1-MY-1-QMS

nuhoom.com

Read the instructions carefully. Remove all the wrappings , staples and straps from the carton. Refer to the hardware and furniture part list for guidance. Make sure that you have all the parts before you start assembling. Place all the wooden furniture parts on a clean, flat and soft surface, such as a carpet or rubbermat to prevent scratches.

CAUTION  
KEEP ALL THE PARTS OUT OF CHILDREN'S REACH.

PART LIST		QTY
1	TOP PANEL	1 PC
2	BOTTOM PANEL	1 PC
3	SIDE PANEL (L)	1 PC
4	SIDE PANEL (R)	1 PC
5	CENTER PANEL	1 PC
6	BONE PANEL UP	1 PC
7	BONE PANEL DOWN	2 PCS
8	BACK BONE	1 PC
9	BACK PANEL	1 PC
10	DRAWER FRONT SMALL (L)	1 PC
11	DRAWER FRONT SMALL (R)	1 PC
12	DRAWER FRONT BIG	3 PCS
13	DRAWER BACK SMALL	2 PCS
14	DRAWER BACK BIG	3 PCS
15	DRAWER SIDE (L)	5 PCS
16	DRAWER SIDE (R)	5 PCS
17	DRAWER BONE	3 PCS
18	DRAWER BOTTOM SMALL	2 PCS
19	DRAWER BOTTOM BIG	3 PCS
20	CABINET LEG	4 PCS

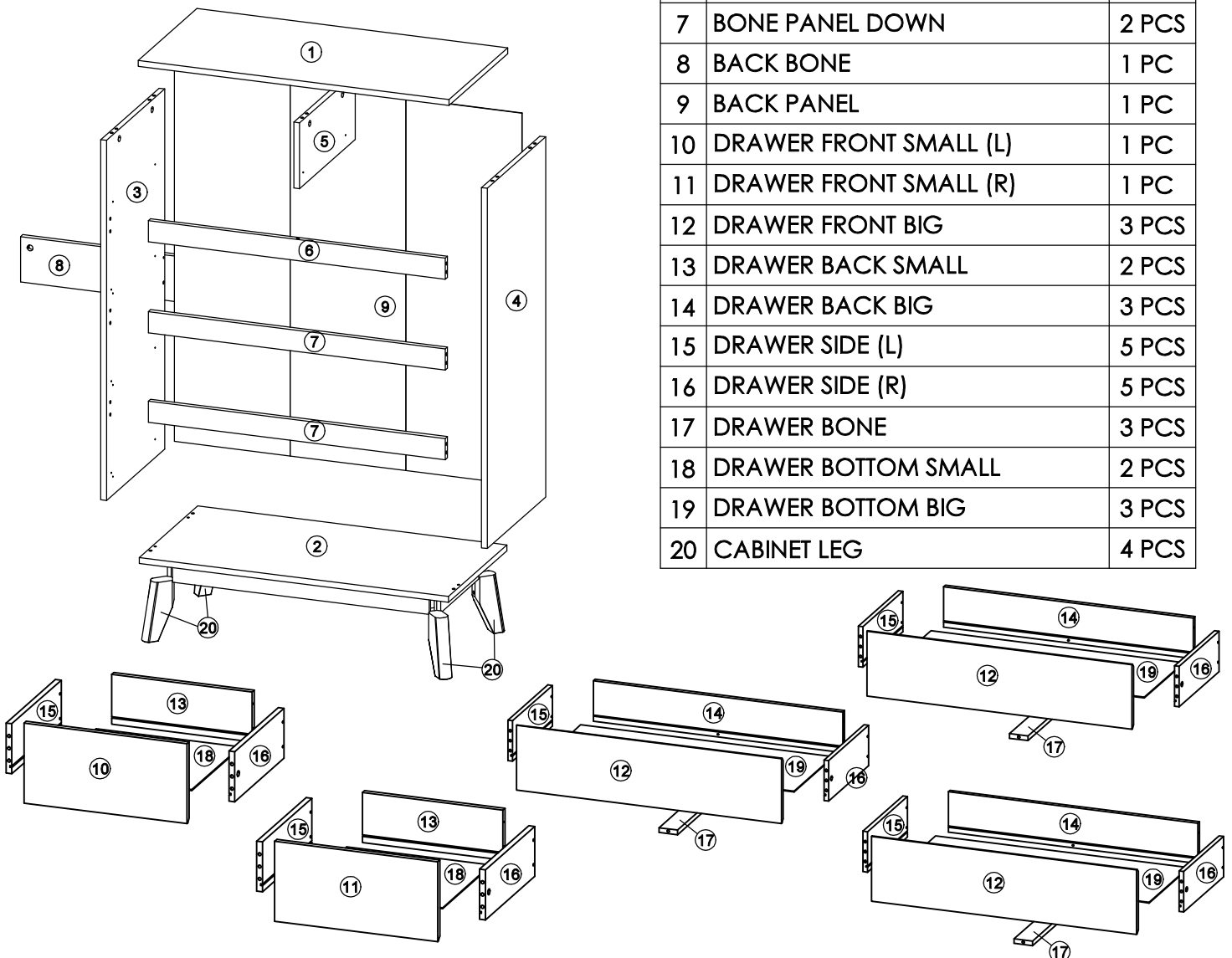

**CODING**  
- 343043



ISO 9001:2015  
Reg. No. 000435-1-MY-1-QMS

nuhoom.com

HARDWARE			
A	MINI FIX	A1  A2  A3	24 SETS
B	M8 X 30MM WOOD DOWEL		45 PCS
C	M6 X 50MM CSK CAP WOOD SCREW		4 PCS
D	ALLEN KEY M4		1 PC
E	M3.5 X 16MM C.B SCREW		78 PCS
F	M4 X 38MM C.B SCREW		20 PCS
G	5/8 NAIL		22 PCS
H	ONE HOLE L BRACKET (2MM)		6 PCS

I	JCBC Screw M6 x 70		8 PCS
J	SPRING WASHER M6		8 PCS
K	FLAT WASHER M6		8 PCS
L	14" DRAWER SLIDE	L1 (L/R) L2 (L/R)	5 SETS
M	TIPPING PACK WITHOUT A1	M1  M2  M3  M4  M5	2 SETS

**SELF-PREPARED TOOLS:** Tools below are NOT included in package.



SCREWDRIVER



HAMMER

**STEP 1**

- Insert hardware **A1** onto panel (3) and (4). (Repeat 4 times.)
- Insert hardware **A2** onto panel (1), (3) and (4). (Repeat 8 times.)
- Insert hardware **B** onto panel (3) and (4). (Repeat 8 times.)

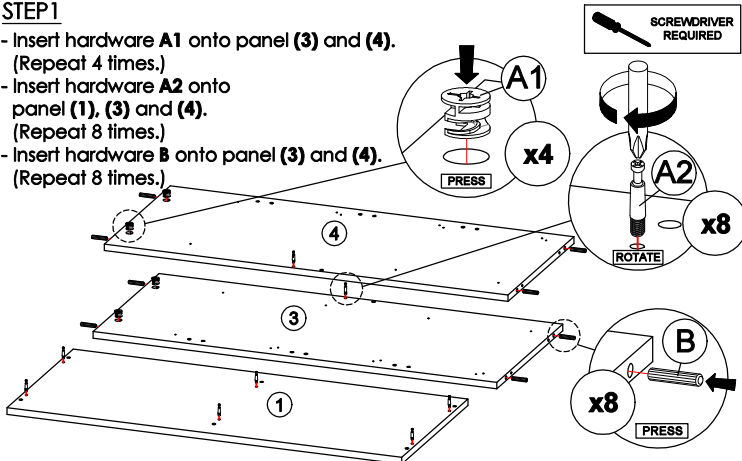

\* Ensure the arrows on hardware **A1** point towards mounting positions.

**STEP 3**

- Insert hardware **A2** onto panel (10), (11), (12) and (14). (Repeat 16 times.)

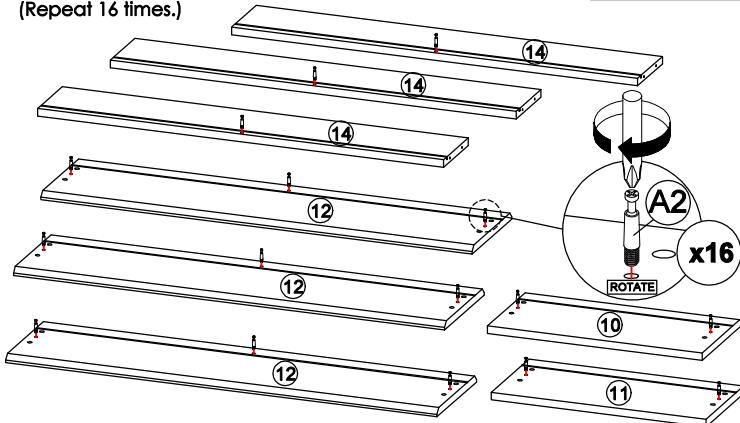

**STEP 2**

- Insert hardware **A1** onto panel (5), (8), (15), (16) and (17). (Repeat 20 times.)
- Insert hardware **B** onto panel (5), (8), (15) and (16). (Repeat 25 times.)

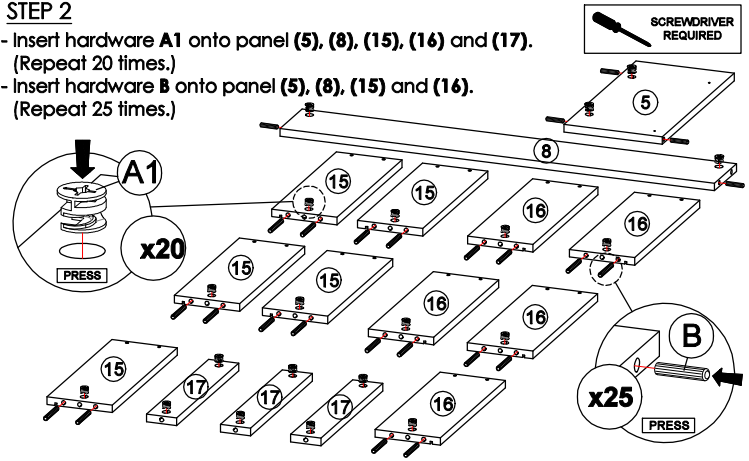

\* Ensure the arrows on hardware **A1** point towards mounting positions.

**STEP 4**

- Assemble hardware **H** to panel (6) and (7) with hardware **E**. (Repeat 6 times.)
- Insert hardware **B** onto panel (6) and (7). (Repeat 12 times.)

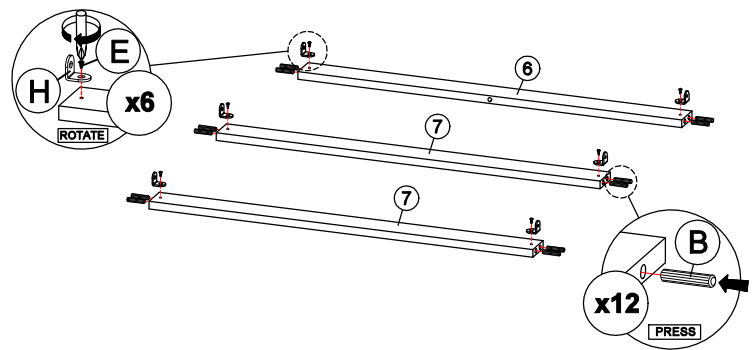

**CODING**  
- 343043

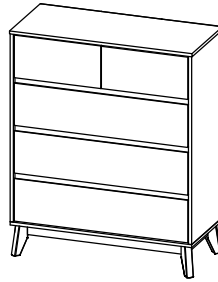

ISO 9001:2015  
Reg. No. 000435-1-MY-1-QMS

nuhoom.com

**STEP 5**

Fix hardware L1 (L/R) into panel (3), (4) and (5) with hardware E.  
(Repeat 3 times for each hardware.)

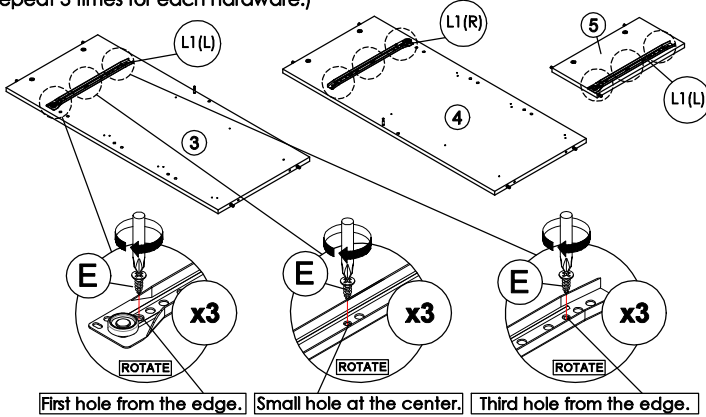

**STEP 6**

Fix hardware L1 (R) into panel (5) with hardware E.  
(Repeat 3 times for each hardware.)

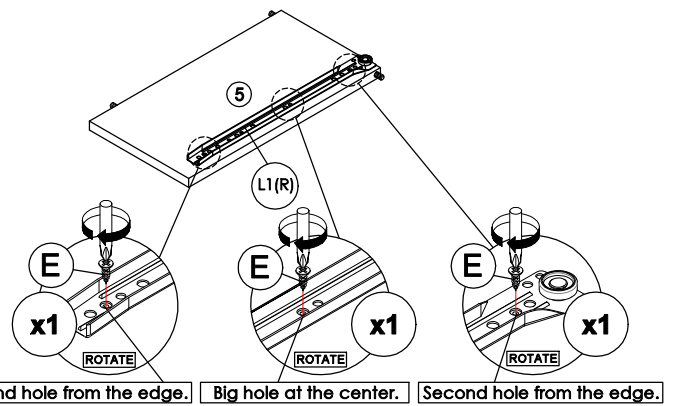

**STEP 7**

Fix hardware L1 (L/R) into panel (3) and (4) with hardware E.  
(Repeat 4 times for each hardware.)

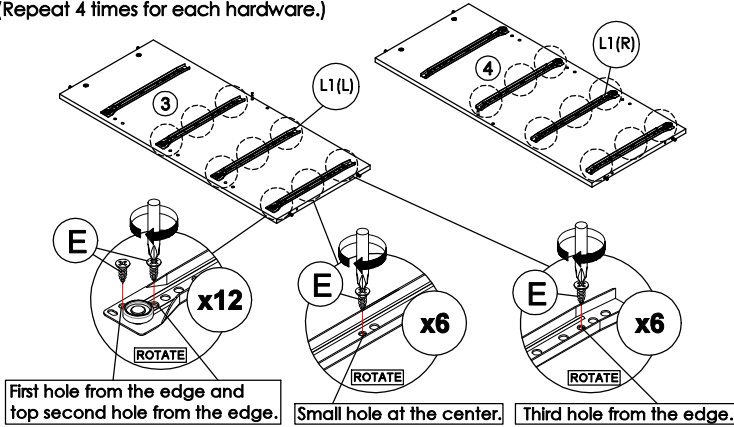

**STEP 8**

- Attach panel (3) and (4) to panel (6), (7) and (8).
- Insert all hardware A2 into A1.
- Rotate all A1 until tight.
- Apply A3 onto all A1.
- (Repeat 2 times.)



OR

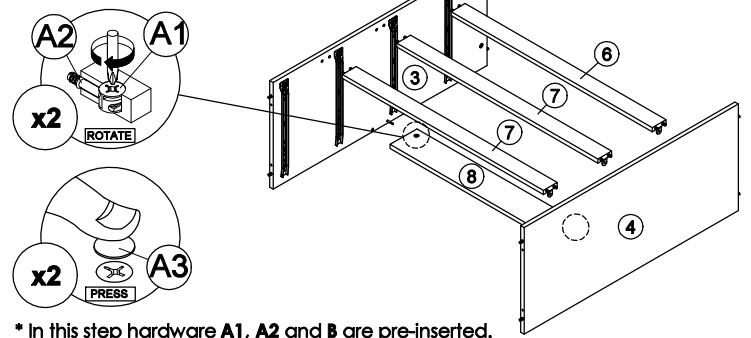

\* In this step hardware A1, A2 and B are pre-inserted.

**STEP 9**

Attach panel (5) to panel (6).  
(Repeat 1 times.)

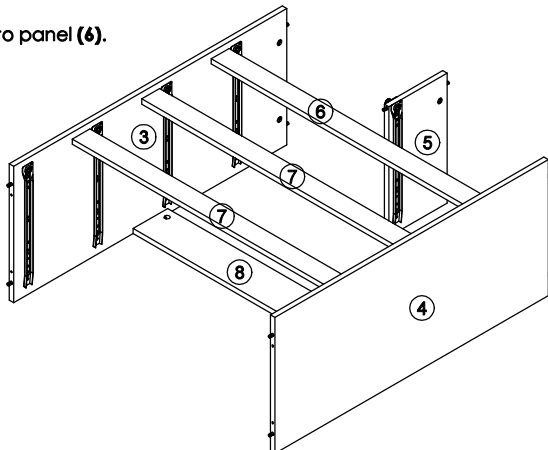

**STEP 10**

- Attach panel (1) to panel (3), (4) and (5).
- Insert all hardware A2 into A1.
- Rotate all A1 until tight.
- Apply A3 onto all A1.
- (Repeat 6 times.)



OR

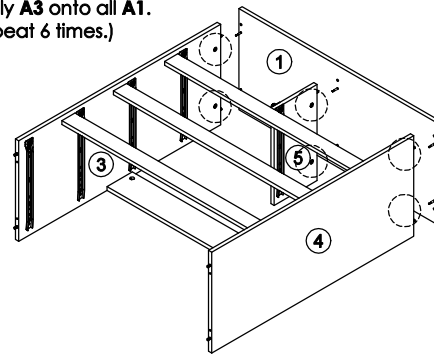

\* In this step hardware A1, A2 and B are pre-inserted.

**CODING**  
- 343043



ISO 9001:2015  
Reg. No. 07045-1-MY-1-QMS

nuhoom.com

**STEP 11**  
Connect panel (2) to panel (3) and (4)  
by using hardware C and D.  
(Repeat 4 times.)

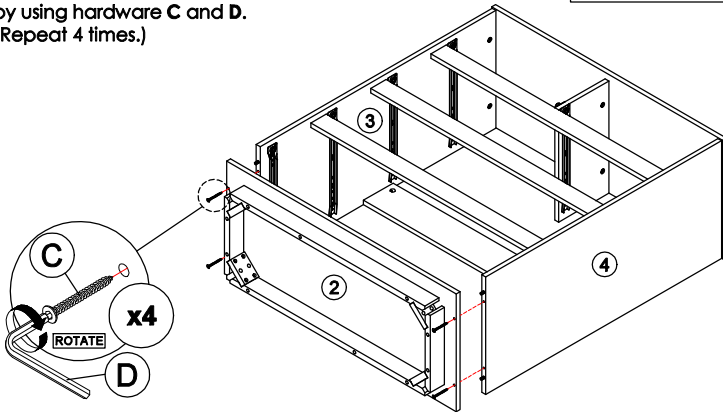

\* In this step hardware B are pre-inserted.

**STEP 12**  
Assemble hardware H to panel (3) and (4)  
with hardware E.  
(Repeat 6 times.)

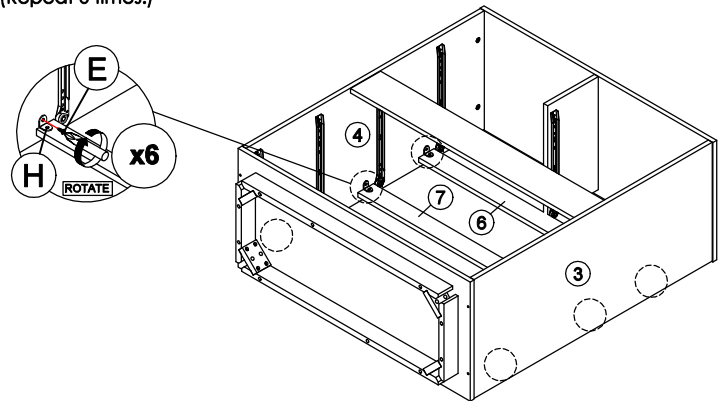

**STEP 13**  
Assemble panel (9) to entire body with hardware G.  
(Repeat 22 times.)

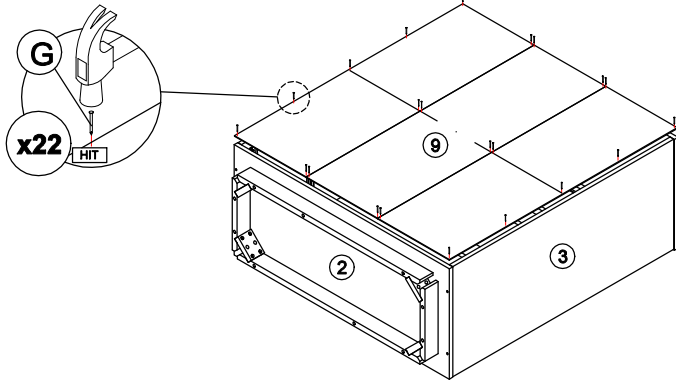

**STEP 14**  
Assemble part (20) into panel (2) by  
using hardware D, I, J and K.  
(Repeat 2 times for each Leg.)

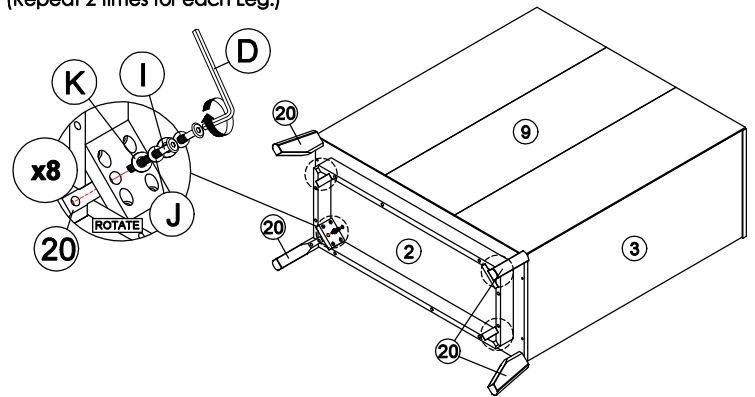

**STEP 15**  
- Assemble panel (13) or (14) with panel (15) and (16)  
by using hardware F.  
(Repeat 16 times.)

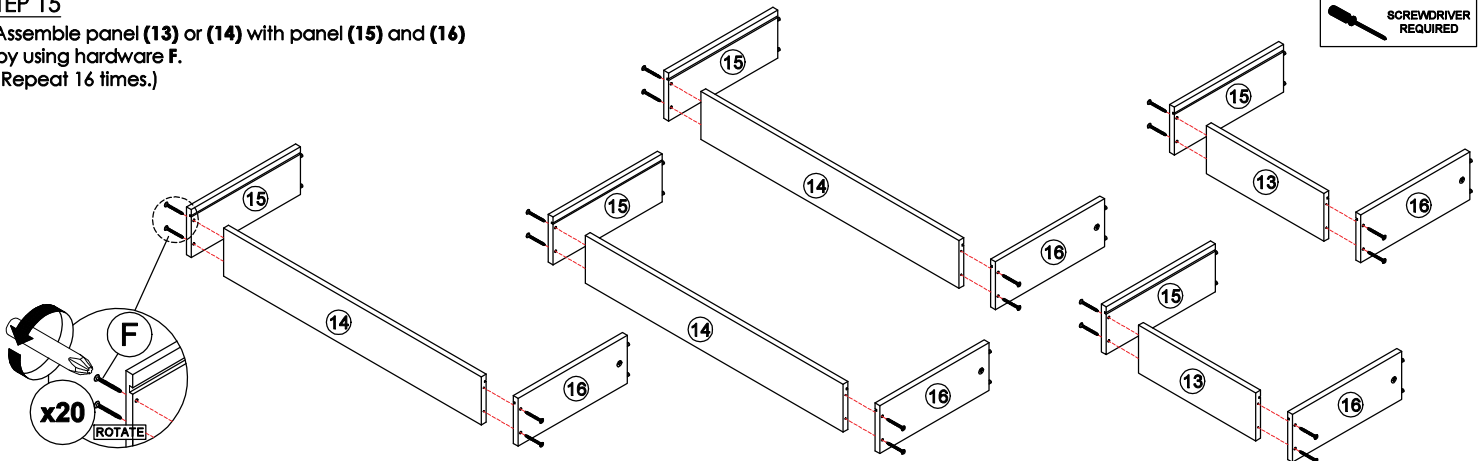

**CODING**  
- 343043



ISO 9001:2015  
Reg. No. 000435-1-MTY-1-QR03

nuhoom.com

**STEP 16**  
Insert the panel (18) and (19) along the slot.  
(Repeat 5 times.)

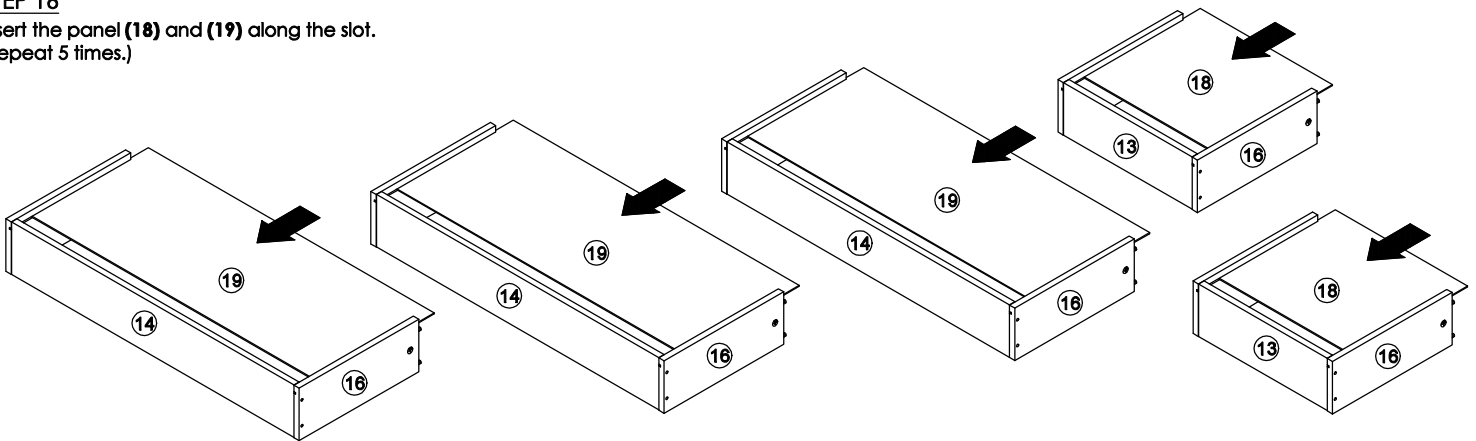

**STEP 17**  
- Attach panel (10) or (11) to panel (15) and (16).  
- Insert all hardware A2 into A1.  
- Rotate all A1 until tight.  
- Apply A3 onto all A1.  
(Repeat 4 times.)

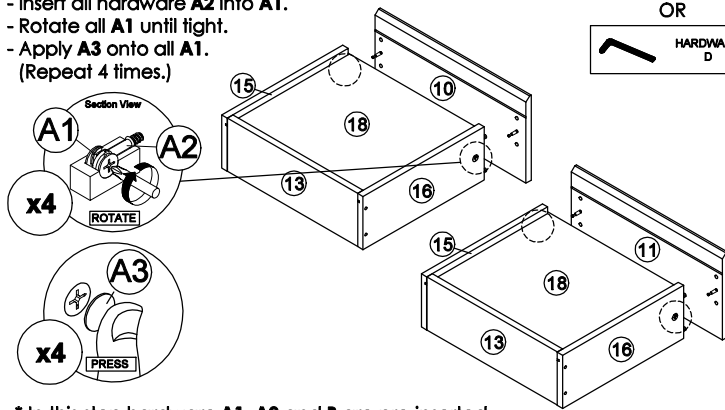

\* In this step hardware A1, A2 and B are pre-inserted.

**STEP 19**  
Assemble hardware L2 (L/R) to panel (15) and (16) by using hardware E.  
(Repeat 3 times for each hardware.)

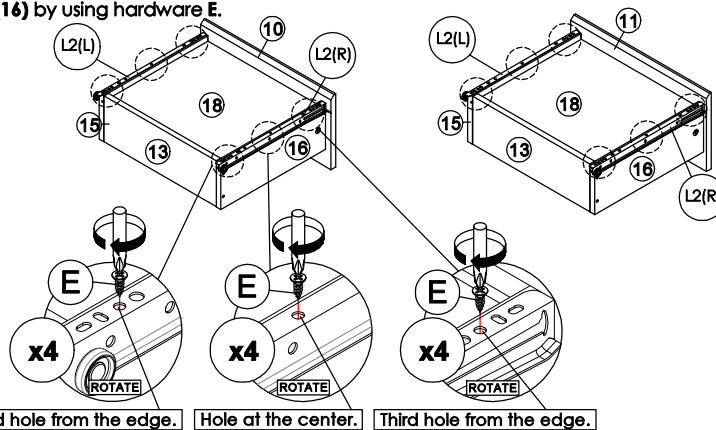

\*Hardware L2 (L/R) shall be leaning against panel (10) or (11) when assembling.

**STEP 18**  
- Attach panel (17) to panel (14).  
- Attach panel (12) to panel (15), (16) and (17).  
- Insert all hardware A2 into A1.  
- Rotate all A1 until tight.  
- Apply A3 onto all A1.  
(Repeat 12 times.)  
\* In this step only show one of the drawers.

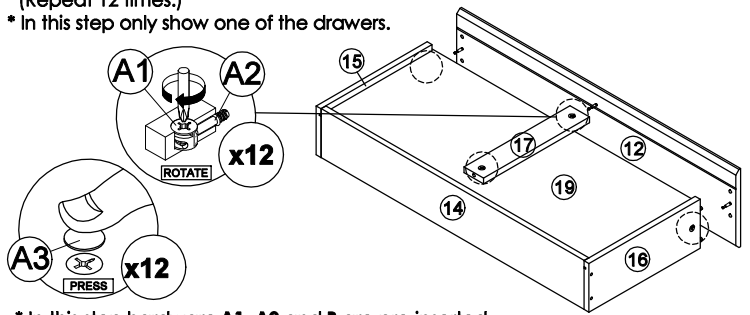

\* In this step hardware A1, A2 and B are pre-inserted.

**CODING**  
- 343043



ISO 9001:2015  
Reg. No. 000435-1-MY-1-QMS

nuhoom.com

**STEP 20**

Assemble hardware **L2 (L/R)** to panel **(15)** and **(16)** by using hardware **E**.  
(Repeat 3 times for each hardware.)

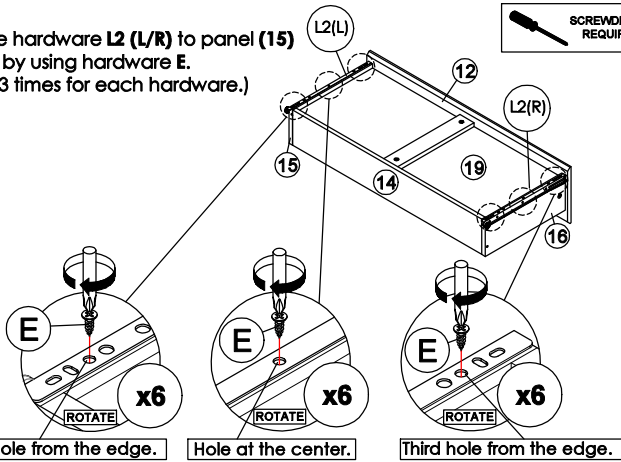

\*Hardware **L2 (L/R)** shall be leaning against panel **(12)** when assembling.

**STEP 21**

Put all the drawer in place along the drawer slides.

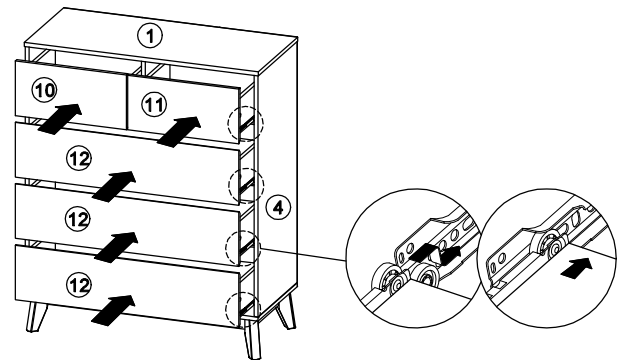

**STEP 22**

Assemble hardware **M1** into panel **(1)** and **(9)** by using hardware **M2**.  
(Repeat 2 times.)

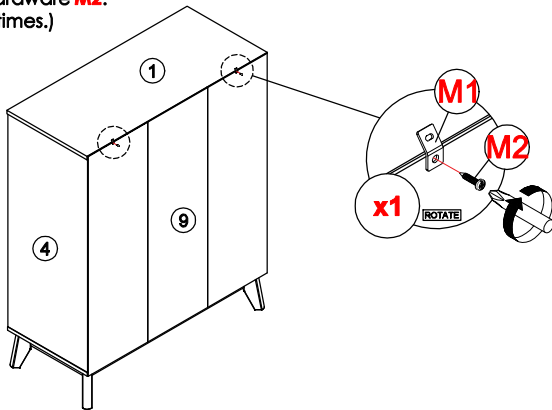

**STEP 23**

- Mark and use the power drill to drill a hole on the wall.  
- Hit hardware **M3** into the wall.  
(Repeat 2 times.)

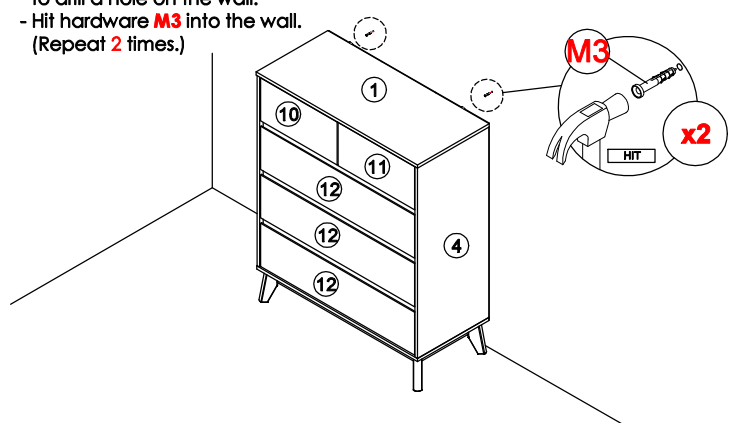

**STEP 24**

- Assemble hardware **M1** to **M3** by using hardware **M4**.  
(Repeat 2 times.)

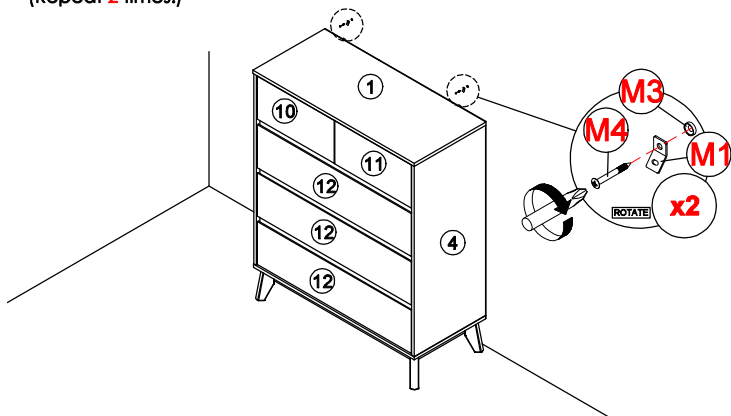

**STEP 25**

- Connect both of the hardware **M1** by using hardware **M5**.  
- Tighten the hardware **M5**.  
(Repeat 2 times.)

