

## CODING

-336078

-336073

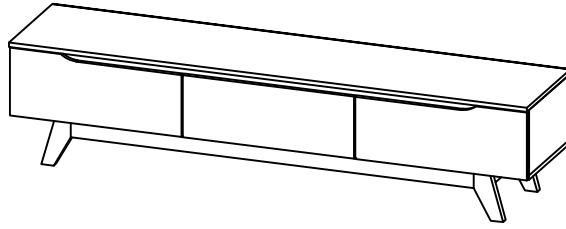

ISO 9001:2015  
Reg. No. 00005-1-INT-1-QMS

nuhoom.com

Read the instructions carefully. Remove all the wrappings, staples and straps from the carton. Refer to the hardware and furniture part list for guidance. Make sure that you have all the parts before you start assembling. Place all the wooden furniture parts on a clean, flat and soft surface, such as a carpet or rubbermat to prevent scratches.

**CAUTION**  
KEEP ALL THE PARTS OUT OF CHILDREN'S REACH.

HARDWARE			
A	MINI FIX	A1  A2  A3	12 SETS
B	M8 X 30MM WOOD DOWEL		24 PCS
C	M6 X 50MM CSK CAP WOOD SCREW		8 PCS
D	ALLEN KEY M4		1 PC
E	M3.5 X 16MM C.B SCREW		36 PCS
F	M4 X 30MM C.B SCREW		2 PCS
G	M4 X 38MM C.B SCREW		38 PCS
H	5/8 NAIL		60 PCS
I	5/8 PVC NAIL LEG		5 PCS
J	14" DRAWER SLIDE	J1 (L/R) J2 (L/R)	3 SETS

PART LIST		QTY
1	TOP PANEL	1 PC
2	BOTTOM PANEL	1 PC
3	SIDE PANEL (L)	1 PC
4	SIDE PANEL (R)	1 PC
5	CENTER PANEL	2 PCS
6	BONE PANEL	1 PC
7	BACK PANEL	1 PC
8	APRON FRONT	1 PC
9	APRON BACK	1 PC
10	APRON BONE	2 PCS
11	CENTER LEG	1 PC
12	DRAWER FRONT (L)	1 PC
13	DRAWER FRONT (R)	1 PC
14	DRAWER FRONT (CENTER)	1 PC
15	DRAWER BACK	3 PCS
16	DRAWER SIDE	6 PCS
17	DRAWER BOTTOM	3 PCS

**SELF-PREPARED TOOLS:** Tools below are NOT included in package.



SCREWDRIVER



HAMMER

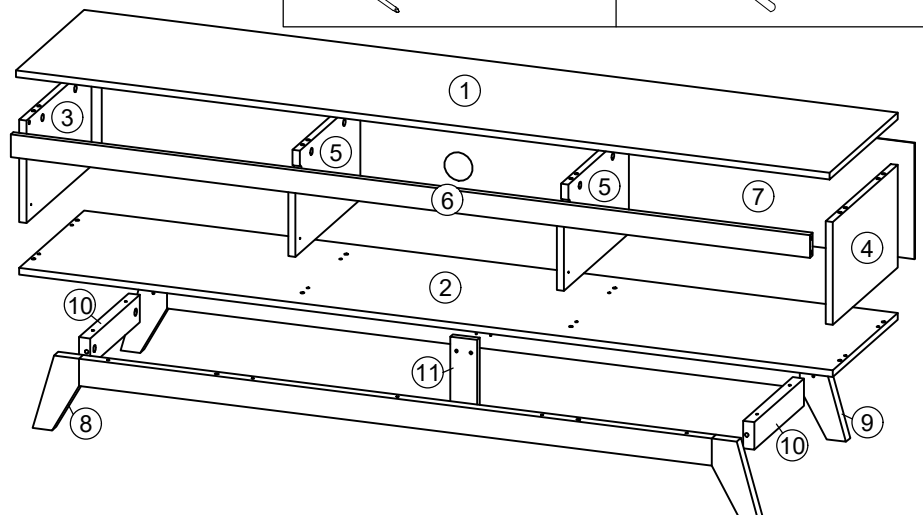
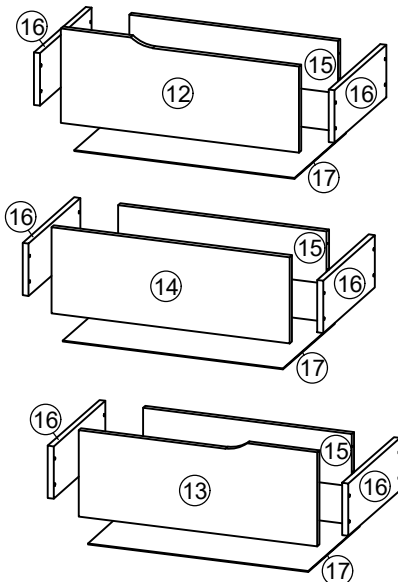

**CODING**  
- 336073

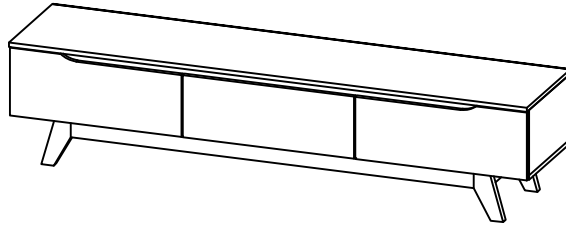

ISO 9001:2015  
Reg. No. 000435-1-2017-1-0285

nuhoom.com

**STEP 1**

- Insert hardware **A1** onto panel (3), (4) and (5). (Repeat 8 times.)
- Insert hardware **A2** onto panel (1). (Repeat 8 times.)
- Insert hardware **B** onto panel (3), (4) and (5). (Repeat 16 times.)

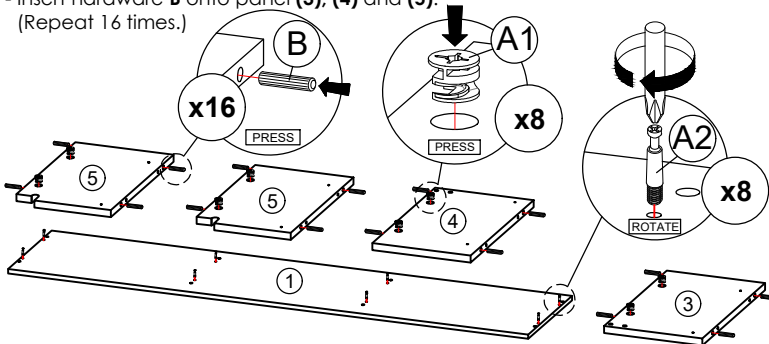

\* Ensure the arrows on hardware **A1** point towards mounting positions.

**STEP 3**

- Fix hardware **J1 (L/R)** into panel (3), (4) and (5) with hardware **E**. (Repeat 3 times for each hardware.)

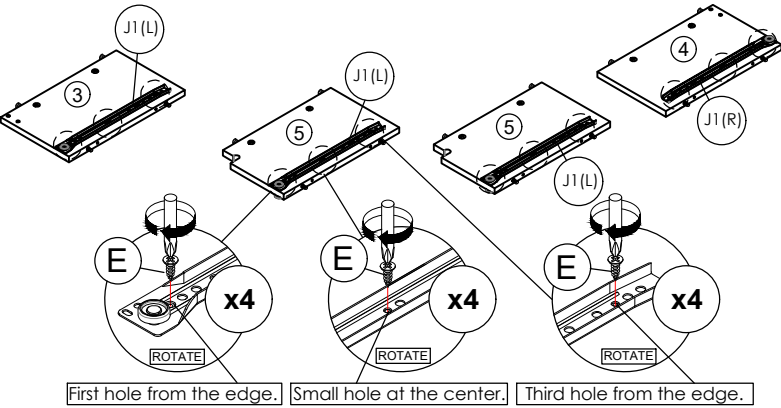

**STEP 5**

- Attach panel (3) and (4) to panel (6). (Repeat 1 times.)

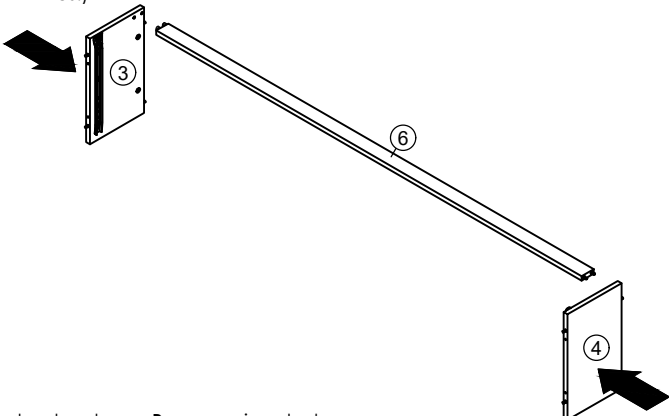

\* In this step hardware **B** are pre-inserted.

**STEP 2**

- Insert hardware **A1** onto panel (10). (Repeat 4 times.)
- Insert hardware **A2** onto panel (8) and (9). (Repeat 4 times.)
- Insert hardware **B** onto panel (6), (8) and (9). (Repeat 8 times.)

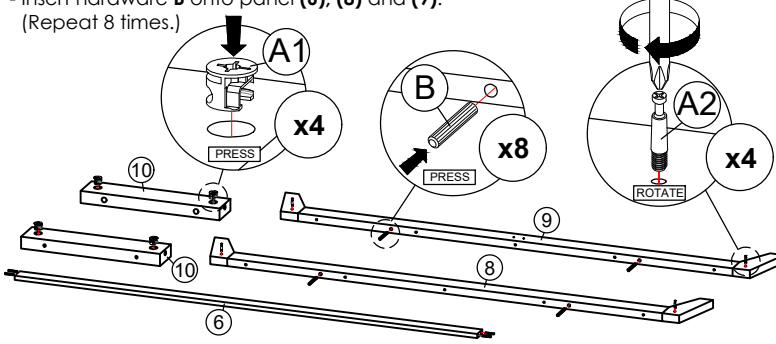

\* Ensure the arrows on hardware **A1** point towards mounting positions.

**STEP 4**

- Fix hardware **J1 (R)** into panel (5) with hardware **E**. (Repeat 3 times for each hardware.)

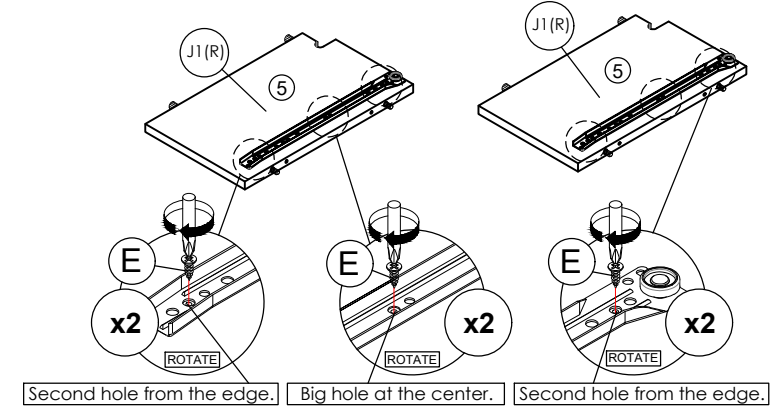

**STEP 6**

- Attach panel (1) to panel (3), (4) and (5).
- Insert all hardware **A2** into **A1**.
- Rotate all **A1** until tight.
- Apply **A3** onto all **A1**. (Repeat 8 times.)



OR

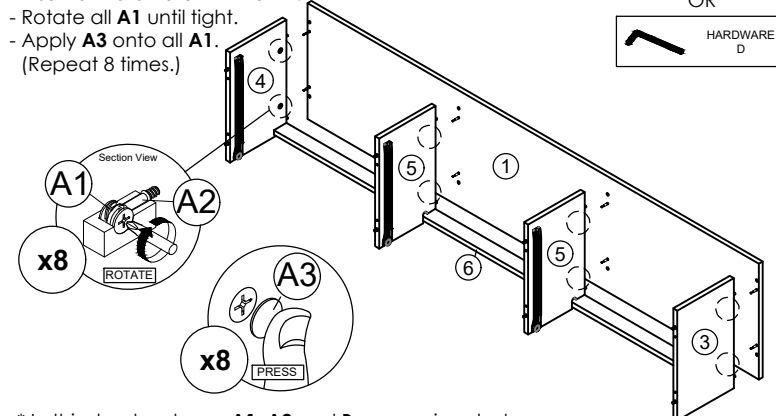

\* In this step hardware **A1**, **A2** and **B** are pre-inserted.

**CODING**  
- 336073

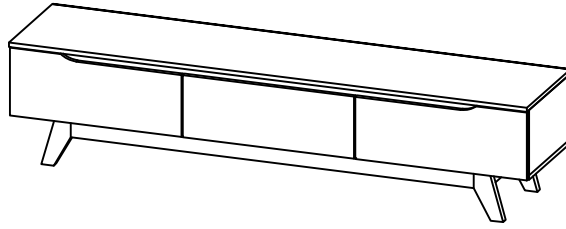

ISO 9001:2015  
Reg. No. 000435-1-MTF-1-QMS

nuhoom.com

**STEP 7**

Connect panel (2) to panel (3), (4) and (5) by using hardware C and D. (Repeat 8 times.)

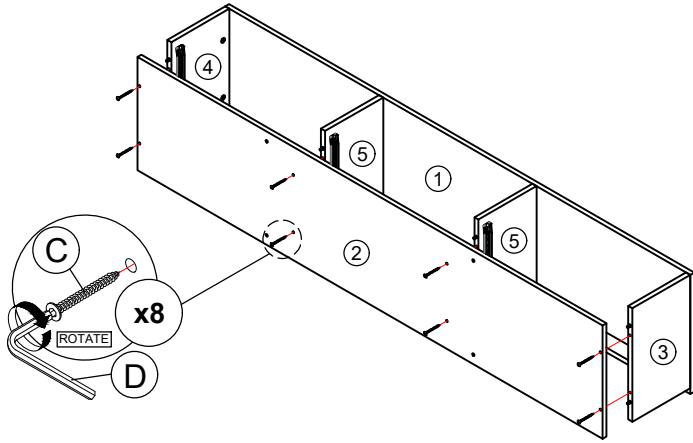

**STEP 8**

- Attach panel (8) and (9) to panel (10).  
- Insert all hardware A2 into A1.  
- Rotate all A1 until tight.  
- Apply A3 onto all A1. (Repeat 4 times.)



OR

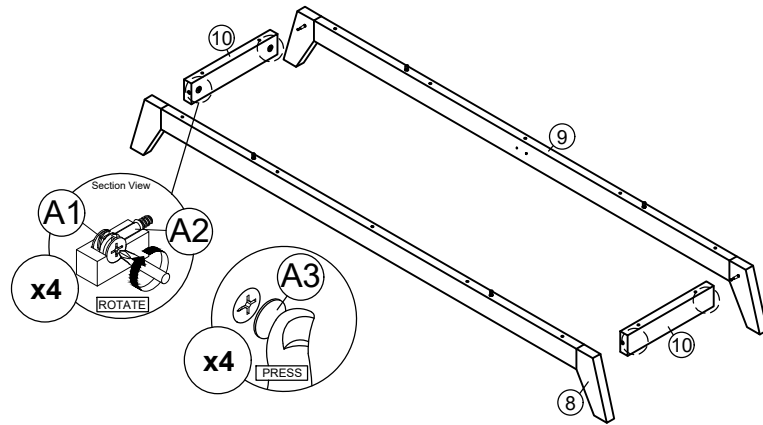

\* In this step hardware B are pre-inserted.

**STEP 9**

Assemble panel (11) with panel (9) by using hardware F. (Repeat 2 times.)

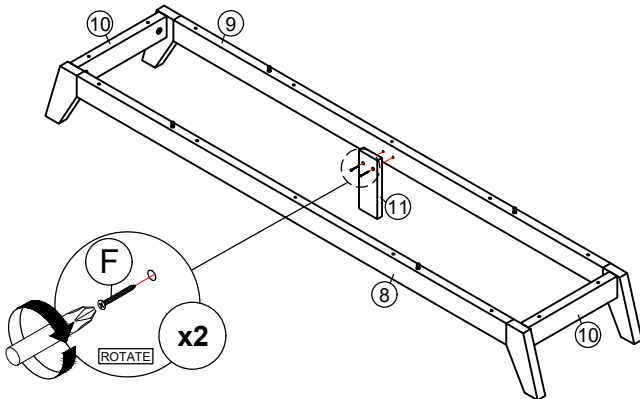

\* In this step hardware A1, A2 and B are pre-inserted.

**STEP 10**

- Assemble panel (7) to entire body with hardware H. (Repeat 36 times.)  
- Hit hardware I into bottom of panel (8), (9) and (11). (Repeat 5 times.)  
- Assemble panel (8), (9) and (10) with panel (2) by using hardware G. (Repeat 14 times.)

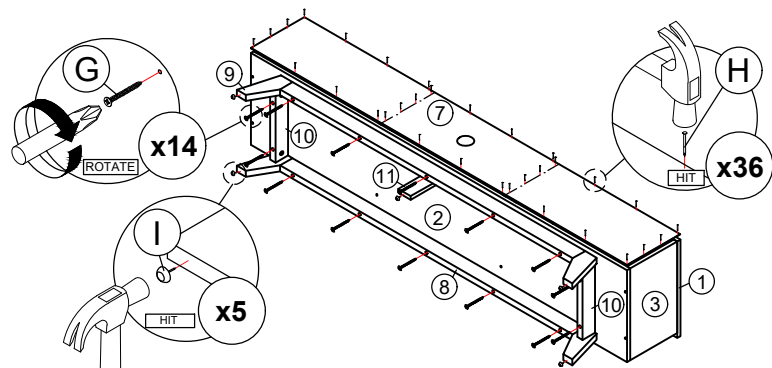

**CODING**  
- 336073

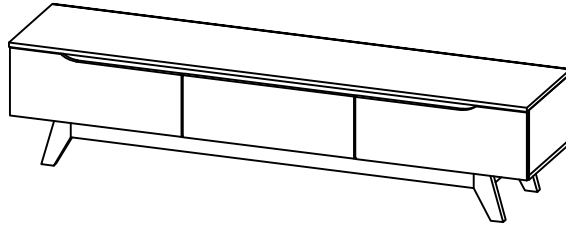

ISO 9001:2015  
Reg. No. 000435-1-MF-1-QMS

nuhoom.com

**STEP 11**

Assemble panel (16) to panel (12) or (13) or (14) and (15) by using hardware G. (Repeat 24 times.)

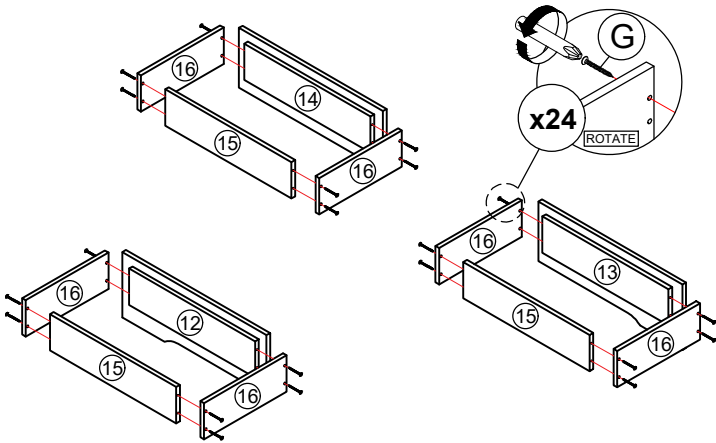

**STEP 12**

Assemble panel (17) to entire body with hardware H. (Repeat 24 times.)

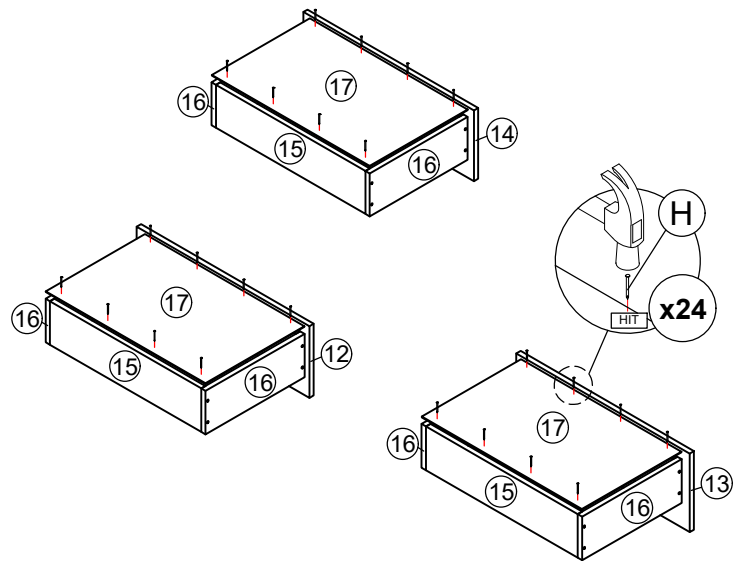

**STEP 13**

Assemble hardware J2 (L/R) to panel (17) by using hardware E. (Repeat 3 times for each hardware.)

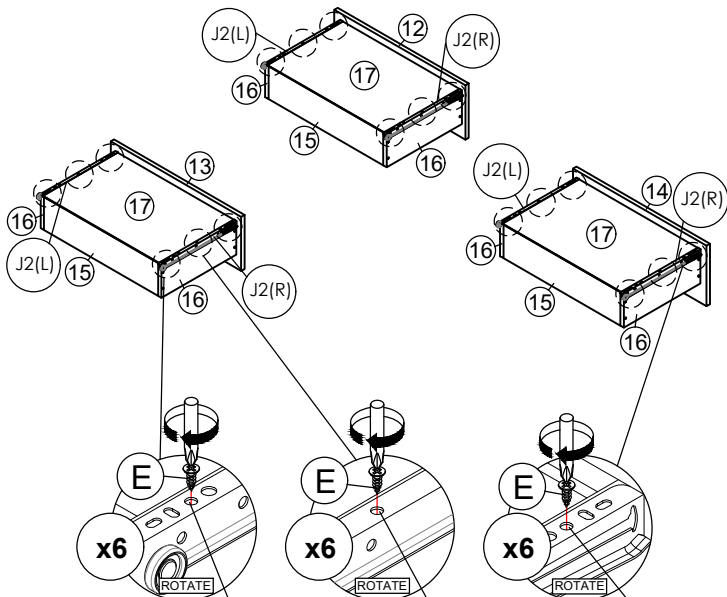

**STEP 14**

Put all the drawer in place along the drawer slides.

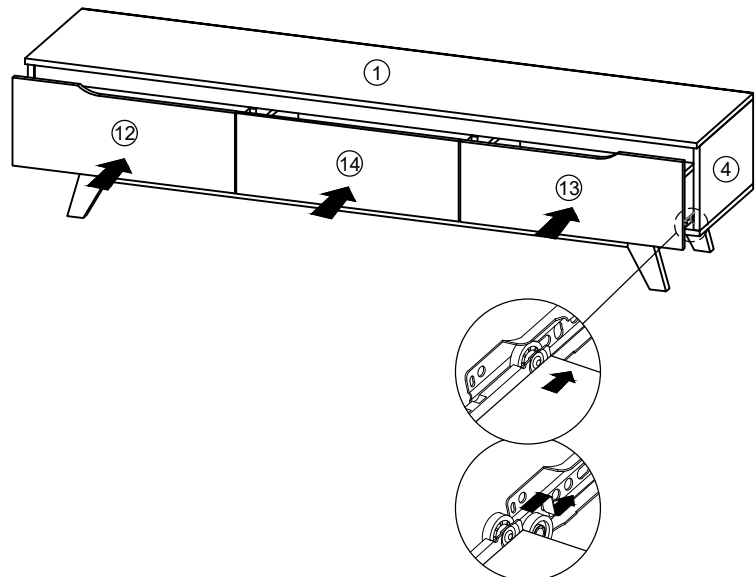

Third hole from the edge. | Hole at the center. | Third hole from the edge.

\*Hardware J2 (L/R) shall be leaning against panel (12) or (13) or (14) when assembling.