

CODING
- 336064

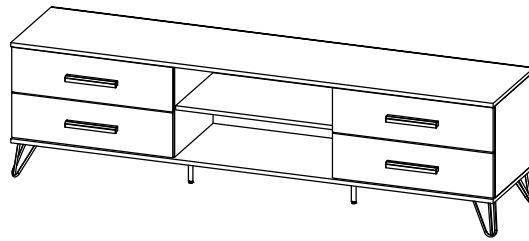

ISO 9001:2015
Reg. No. 09035-1-017-1-QMS

nuhoom.com

Read the instructions carefully. Remove all the wrappings , staples and straps from the carton. Refer to the hardware and furniture part list for guidance. Make sure that you have all the parts before you start assembling. Place all the wooden furniture parts on a clean, flat and soft surface, such as a carpet or rubbermat to prevent scratches.

CAUTION
KEEP ALL THE PARTS OUT OF CHILDREN'S REACH.

PART LIST		QTY
1	TOP PANEL	1 PC
2	BOTTOM PANEL	1 PC
3	SIDE PANEL (L)	1 PC
4	SIDE PANEL (R)	1 PC
5	CENTER PANEL-L	1 PC
6	CENTER PANEL-R	1 PC
7	SHELF PANEL	1 PC
8	BACK PANEL	1 PC
9	DRAWER FRONT	4 PCS
10	DRAWER BACK	4 PCS
11	DRAWER SIDE	8 PCS
12	BOTTOM DRAWER	4 PCS

HARDWARE			
A	MINI FIX	A1 A2 A3	8 SETS
B	M8 X 30MM WOOD DOWEL		16 PCS
C	M6 X 50MM CSK CAP WOOD SCREW		8 PCS
D	ALLEN KEY M4		1 PC
E	M3.5 X 16MM C.B SCREW		72 PCS
F	M4 X 38MM C.B SCREW		32 PCS
G	M4 X 45MM C.B SCREW		12 PCS
H	METAL SHELF SUPPORT		4 PCS
I	5/8 NAIL		68 PCS
J	14" DRAWER SLIDE	J1 (L/R) J2 (L/R)	4 SETS
K	METAL LEG 90 x 90 x 8 x H145MM		4 PCS
L	METAL LEG 50 x 50 x H140MM (CENTER)		2 PCS
M	WOOD HANDLE (190MM)		4 PCS

TIPPING PACK WITH AI		2 SETS
----------------------	--	--------

SELF-PREPARED TOOLS: Tools below are NOT included in package.	
SCREWDRIVER	HAMMER

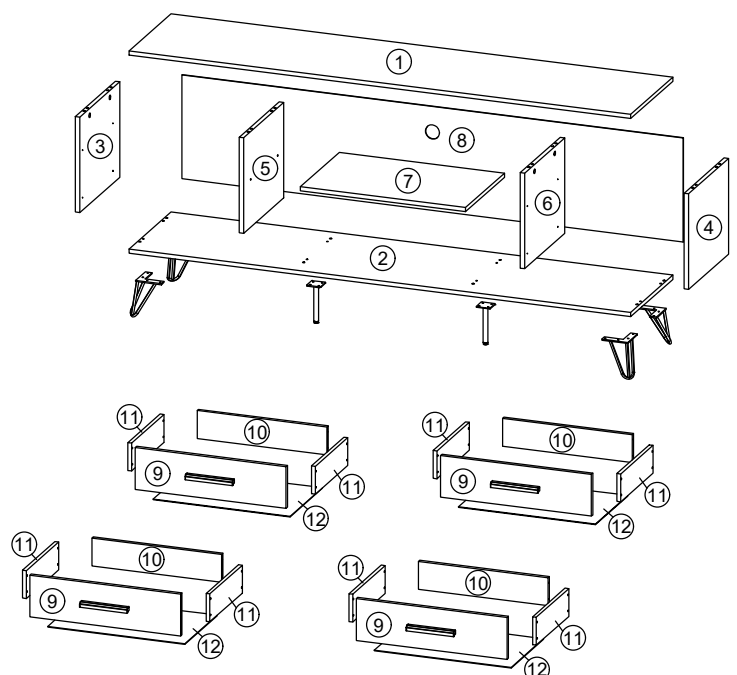

CODING
- 336064

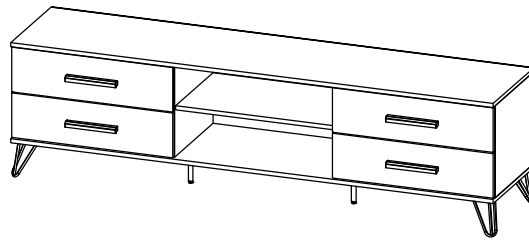

ISO 9001:2015
Reg. No. 09035-1-017-1-QMS

nuhoom.com

STEP 1
Insert hardware **A2** onto panel **(1)**.
(Repeat 8 times.)

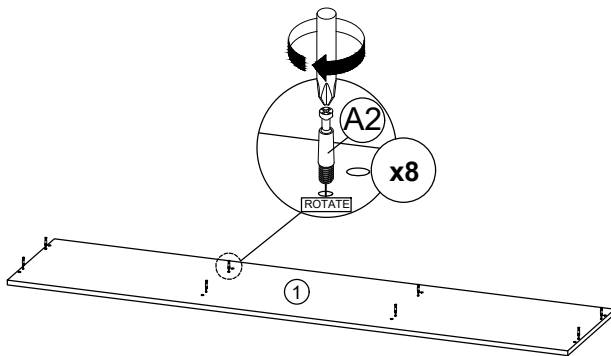

STEP 2
- Insert hardware **A1** onto panel **(3), (4), (5)** and **(6)**.
(Repeat 8 times.)
- Insert hardware **B** onto panel **(3), (4), (5)** and **(6)**.
(Repeat 16 times.)

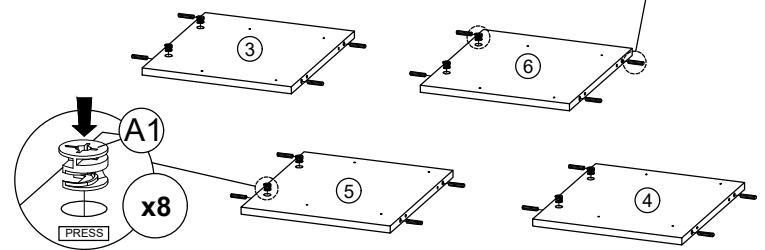
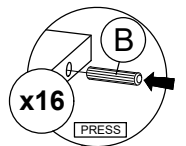

* Ensure the arrows on hardware **A1** point towards mounting positions.

STEP 3
Fix hardware **J1 (L/R)** into panel **(3), (4), (5)** and **(6)** with hardware **E**.
(Repeat 3 times for each hardware.)

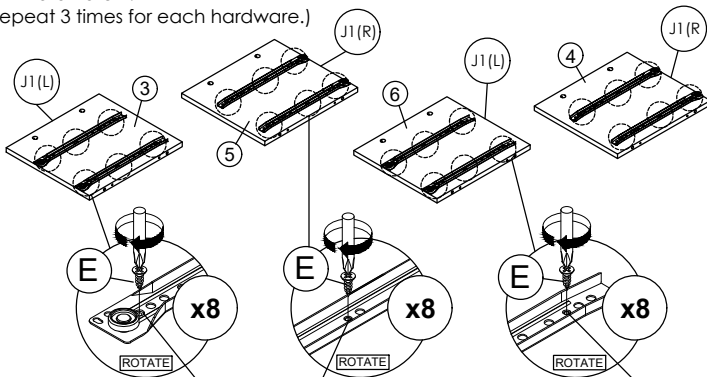

First hole from the edge. Small hole at the center. Third hole from the edge.

STEP 4
- Attach panel **(1)** to panel **(3), (4), (5)** and **(6)**.
- Insert all hardware **A2** into **A1**.
- Rotate all **A1** until tight.
- Apply **A3** onto all **A1**.
(Repeat 8 times.)

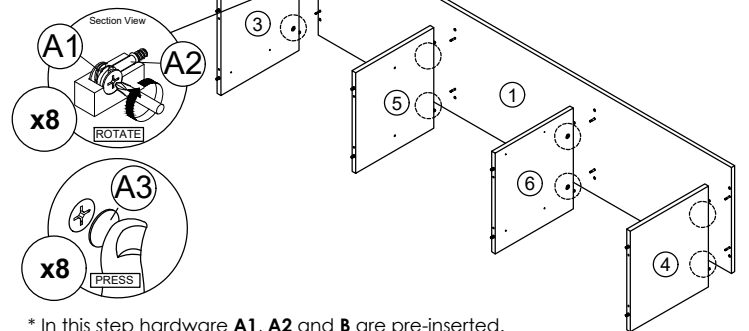

* In this step hardware **A1, A2** and **B** are pre-inserted.

STEP 5
Connect panel **(2)** to panel **(3), (4), (5)** and **(6)** by using hardware **C** and **D**.
(Repeat 8 times.)

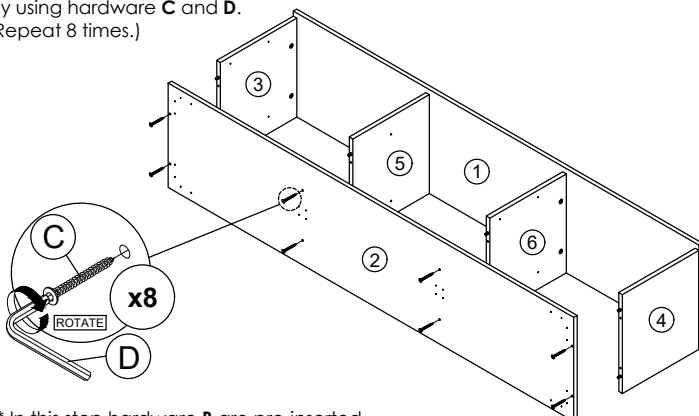

* In this step hardware **B** are pre-inserted.

STEP 6
Assemble hardware **K** and **L** onto panel **(2)** by using hardware **E**.
(Repeat 4 times for each hardware.)

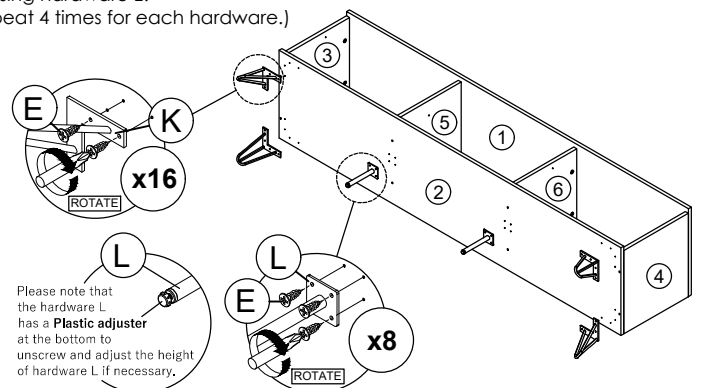

Please note that the hardware **L** has a **Plastic adjuster** at the bottom to unscrew and adjust the height of hardware **L** if necessary.

SAMOS

CODING
- 336064

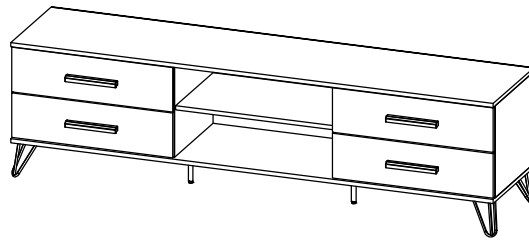

ISO 9001:2015
Reg. No. 09035-1-017-1-Q005

nuhoom.com

STEP 7
Assemble panel (8) to entire body with hardware I.
(Repeat 28 times.)

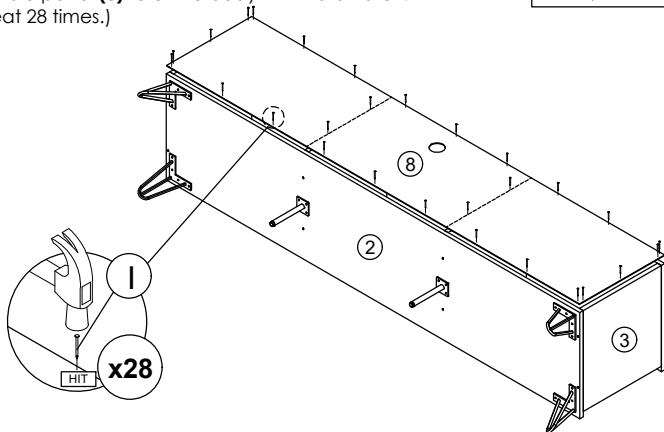

STEP 8
Insert hardware H into mounting positions on panel (5) and (6) by hand.
(Repeat 4 times.)

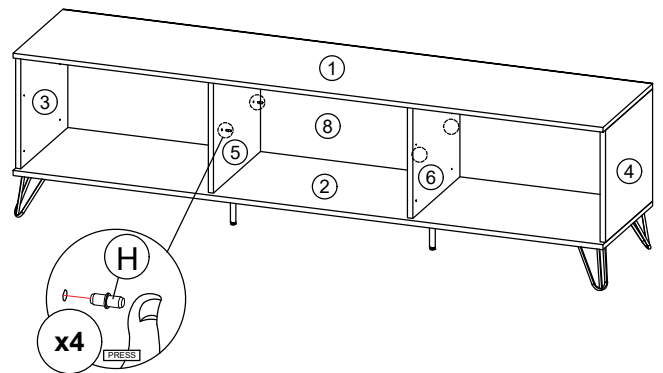

STEP 9
Assemble the panel (7) into between panel (5) and (6).
(Repeat 1 times.)

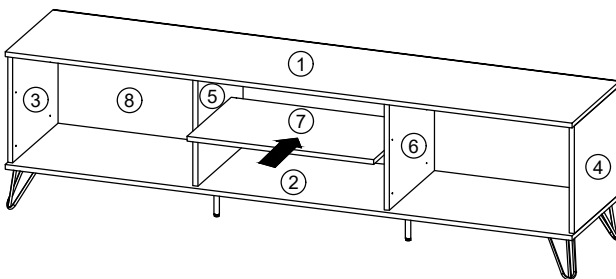

STEP 10
Fix hardware M onto panel (9) by using hardware G.
(Repeat 3 times for each hardware.)

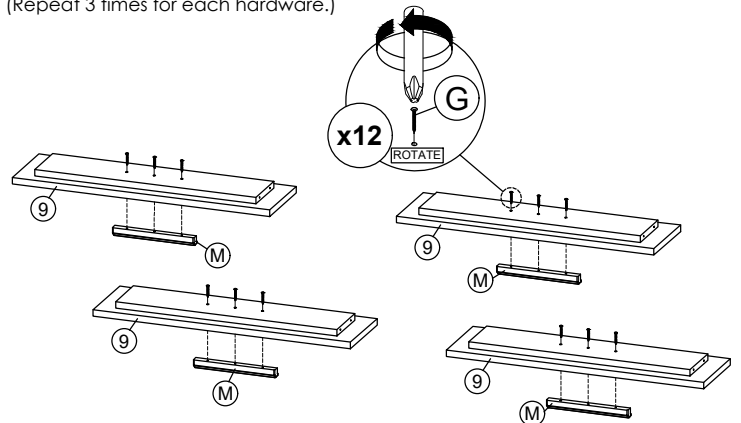

* In this step hardware H are pre-inserted.

STEP 11
Assemble panel (11) with panel (9) and (10)
by using hardware F.
(Repeat 32 times.)

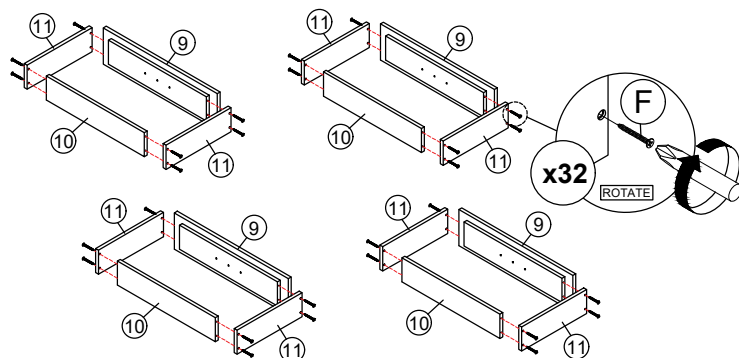

STEP 12
Assemble panel (12) to entire body with hardware I.
(Repeat 40 times.)

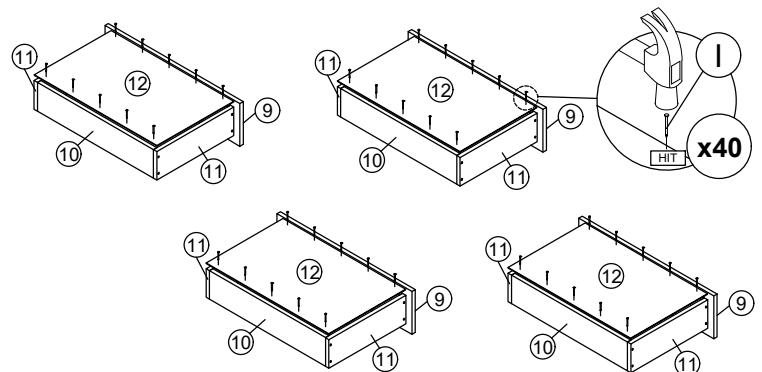

CODING
- 336064

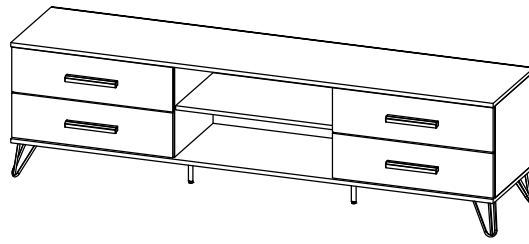

ISO 9001:2015
Reg. No. 09035-1-017-1-Q005

nuhoom.com

STEP 13

Assemble hardware **J2 (L/R)** to panel **(12)**
by using hardware **E**.
(Repeat 3 times for each hardware.)

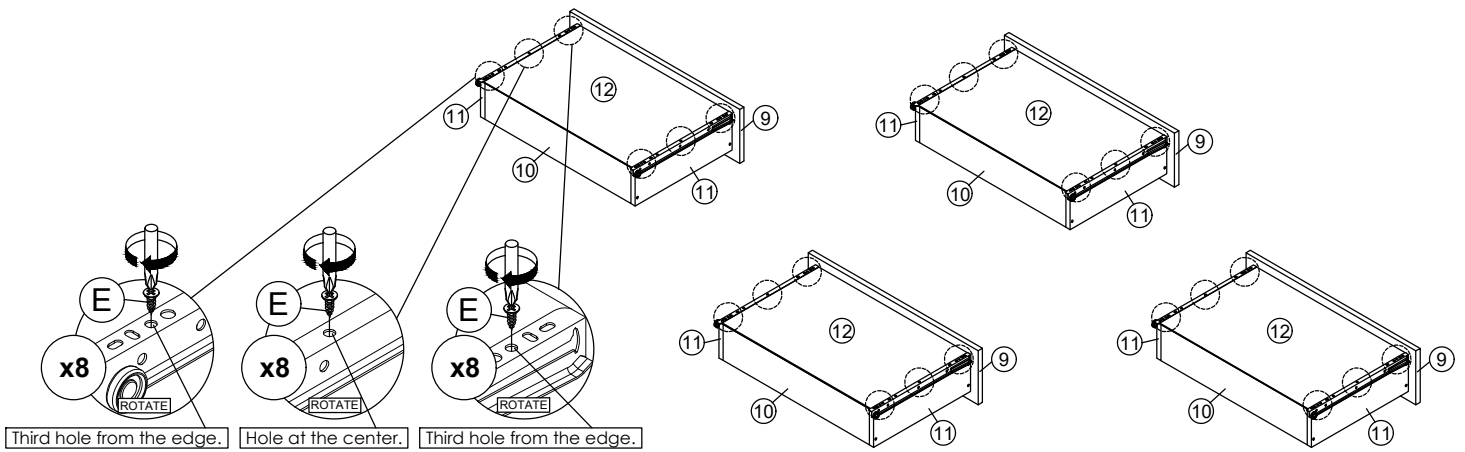
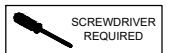

*Hardware **J2 (L/R)** shall be leaning against panel **(9)** when assembling.

STEP 14

Put all the drawer in place along the drawer slides.

