

CODING

-133116

-133113

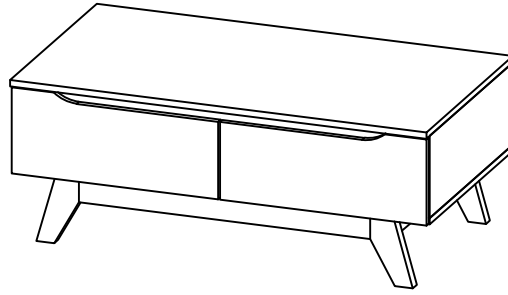

ISO 9001:2015
Reg. No. 00005-1-2017-1-QMS

nuhoom.com

Read the instructions carefully. Remove all the wrappings, staples and straps from the carton. Refer to the hardware and furniture part list for guidance. Make sure that you have all the parts before you start assembling. Place all the wooden furniture parts on a clean, flat and soft surface, such as a carpet or rubbermat to prevent scratches.

CAUTION
KEEP ALL THE PARTS OUT OF CHILDREN'S REACH.

HARDWARE			
A	MINI FIX	A1 A2 A3	14 SETS
B	M8 X 30MM WOOD DOWEL		22 PCS
C	M6 X 50MM CSK CAP WOOD SCREW		8 PCS
D	ALLEN KEY M4		1 PC
E	M3.5 X 16MM C.B SCREW		24 PCS
F	M4 X 38MM C.B SCREW		26 PCS
G	5/8 NAIL		16 PCS
H	5/8 PVC NAIL LEG		4 PCS
I	14" DRAWER SLIDE	I1 (L/R) I2 (L/R)	2 SETS

SELF-PREPARED TOOLS: Tools below are NOT included in package.	
	SCREWDRIVER
	HAMMER

PART LIST		QTY
1	TOP PANEL	1 PC
2	BOTTOM PANEL	1 PC
3	SIDE PANEL (L)	1 PC
4	SIDE PANEL (R)	1 PC
5	CENTER PANEL	1 PC
6	MIDDLE PANEL	1 PC
7	BONE PANEL	1 PC
8	APRON FRONT	1 PC
9	APRON BACK	1 PC
10	APRON BONE	2 PCS
11	DRAWER FRONT (L)	1 PC
12	DRAWER FRONT (R)	1 PC
13	DRAWER BACK	2 PCS
14	DRAWER SIDE	4 PCS
15	DRAWER BOTTOM	2 PCS

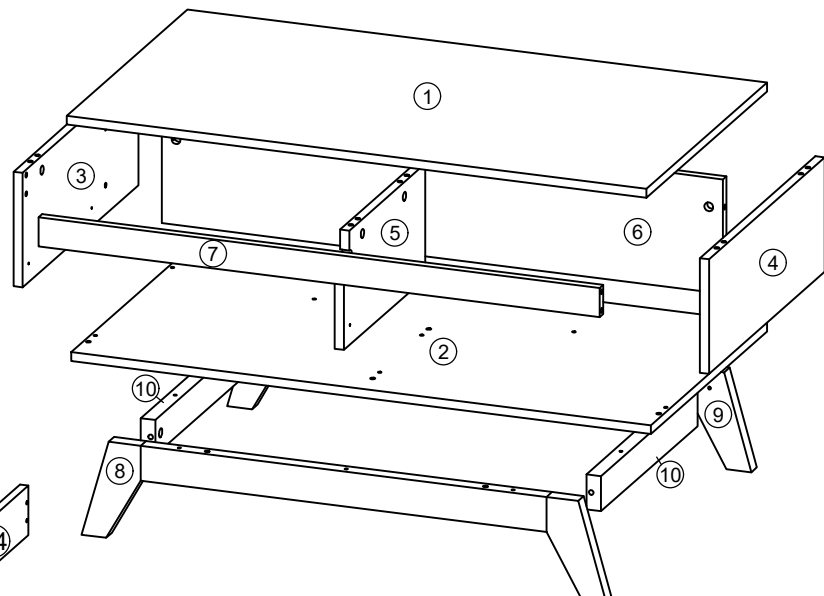
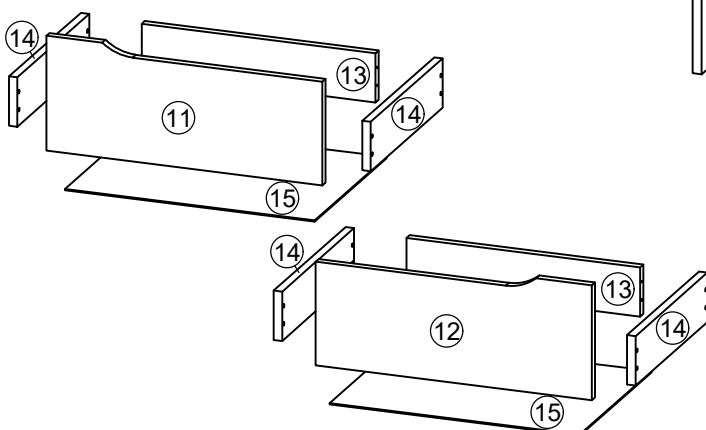

CODING
- 133113

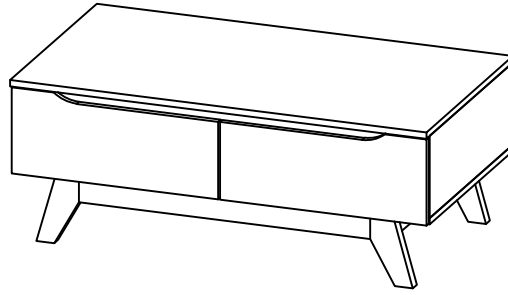

ISO 9001:2015
Reg. No. 00005-1-INT-1-QMS

nuhoom.com

STEP 1

- Insert hardware **A1** onto panel (3), (4), (5) and (6). (Repeat 10 times.)
- Insert hardware **A2** onto panel (1), (3) and (4). (Repeat 10 times.)
- Insert hardware **B** onto panel (3), (4), (5) and (6). (Repeat 8 times.)

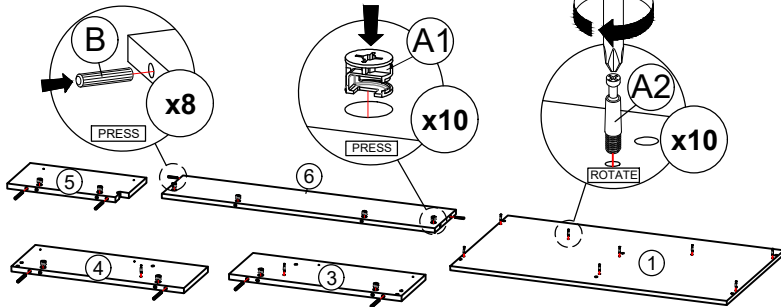

* Ensure the arrows on hardware **A1** point towards mounting positions.

STEP 3

- Fix hardware **I1 (L/R)** into panel (3), (4) and (5) with hardware **E**. (Repeat 3 times for each hardware.)

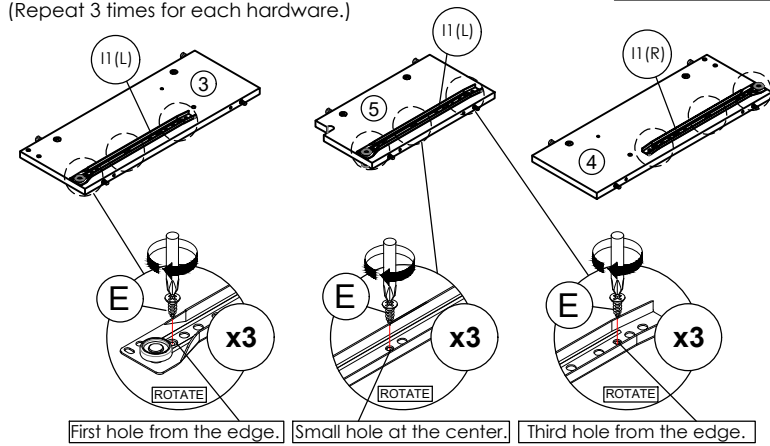

STEP 5

- Attach panel (3) and (4) to panel (6) and (7).
- Insert all hardware **A2** into **A1**.
- Rotate all **A1** until tight.
- Apply **A3** onto all **A1**. (Repeat 2 times.)



OR

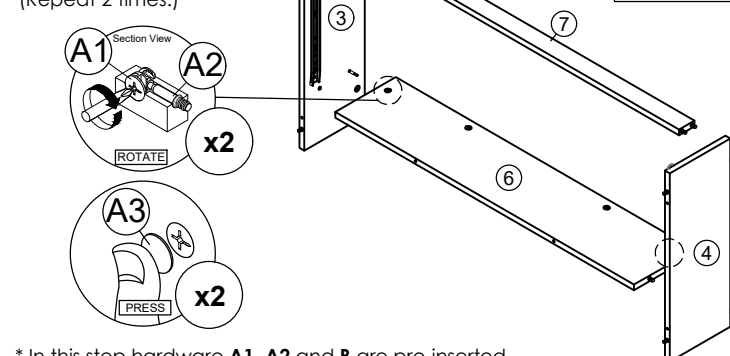

* In this step hardware **A1**, **A2** and **B** are pre-inserted.

STEP 2

- Insert hardware **A1** onto panel (10). (Repeat 4 times.)
- Insert hardware **A2** onto panel (8) and (9). (Repeat 4 times.)
- Insert hardware **B** onto panel (7), (8) and (9). (Repeat 8 times.)

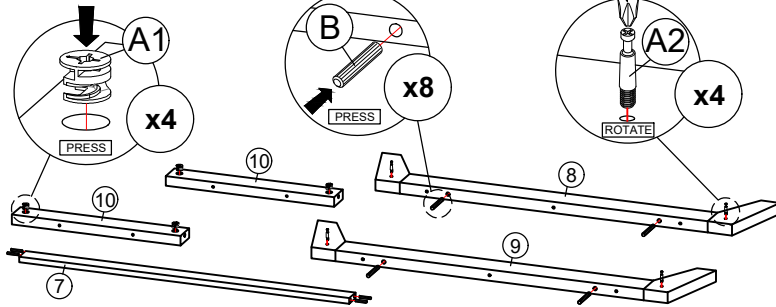

* Ensure the arrows on hardware **A1** point towards mounting positions.

STEP 4

- Fix hardware **I1 (R)** into panel (5) with hardware **E**. (Repeat 3 times for each hardware.)

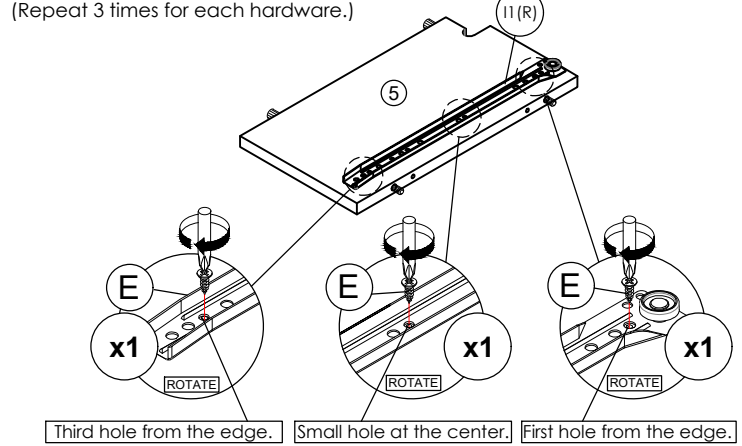

STEP 6

- Attach panel (1) to panel (3), (4), (5) and (6).
- Insert all hardware **A2** into **A1**.
- Rotate all **A1** until tight.
- Apply **A3** onto all **A1**. (Repeat 8 times.)



OR

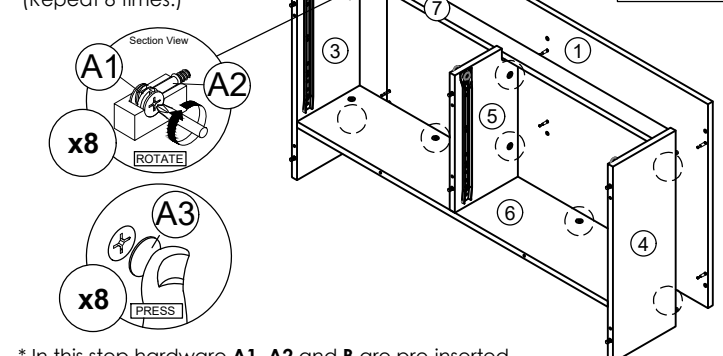

* In this step hardware **A1**, **A2** and **B** are pre-inserted.

CODING
- 133113

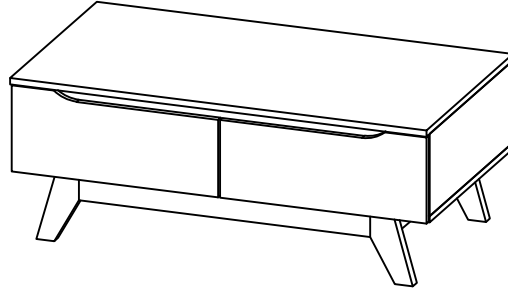

ISO 9001:2015
Reg. No. 00045-1-2017-1-0285

nuhoom.com

STEP 7

Connect panel (2) to panel (3), (4), (5) and (6) by using hardware C and D. (Repeat 8 times.)

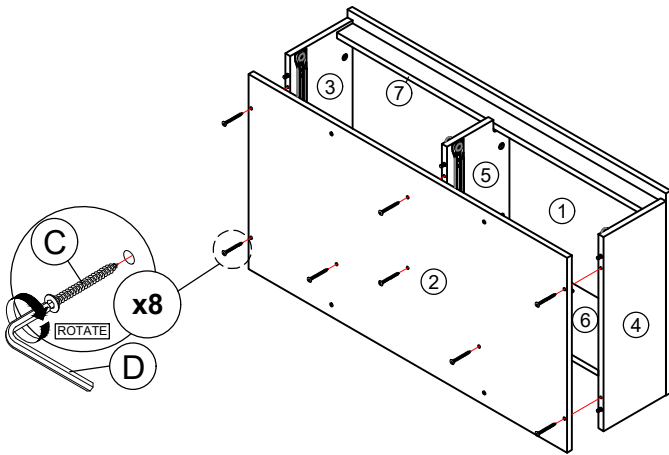

STEP 8

- Attach panel (8) and (9) to panel (10).
- Insert all hardware A2 into A1.
- Rotate all A1 until tight.
- Apply A3 onto all A1. (Repeat 4 times.)



OR

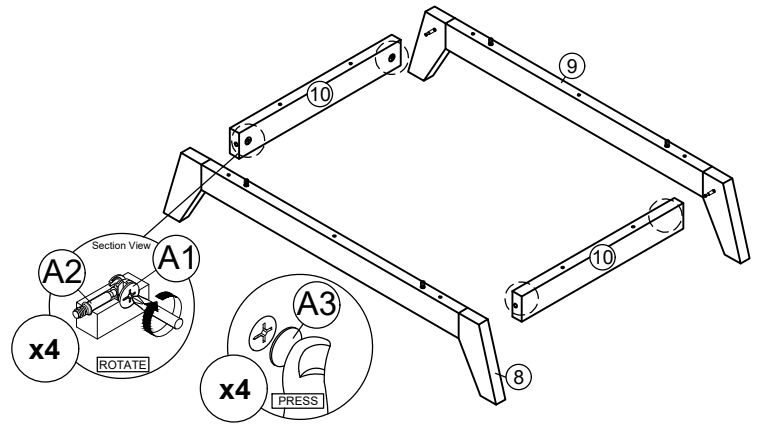

* In this step hardware B are pre-inserted.

STEP 9

Assemble panel (8), (9) and (10) with panel (2) by using hardware F. (Repeat 10 times.)

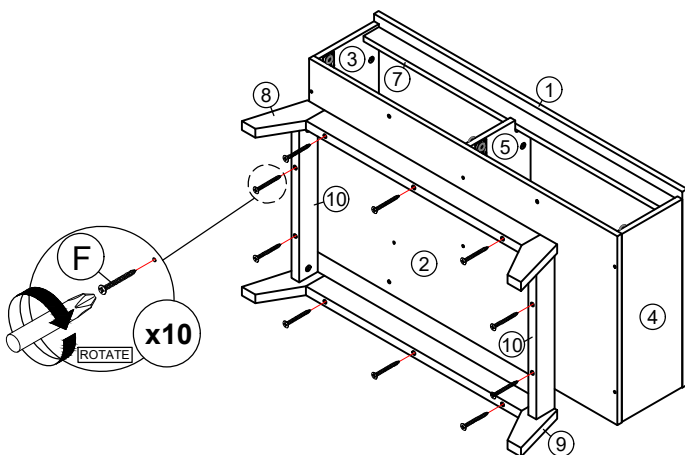

* In this step hardware A1, A2 and B are pre-inserted.

STEP 10

Hit hardware H into bottom of panel (8) and (9). (Repeat 4 times.)

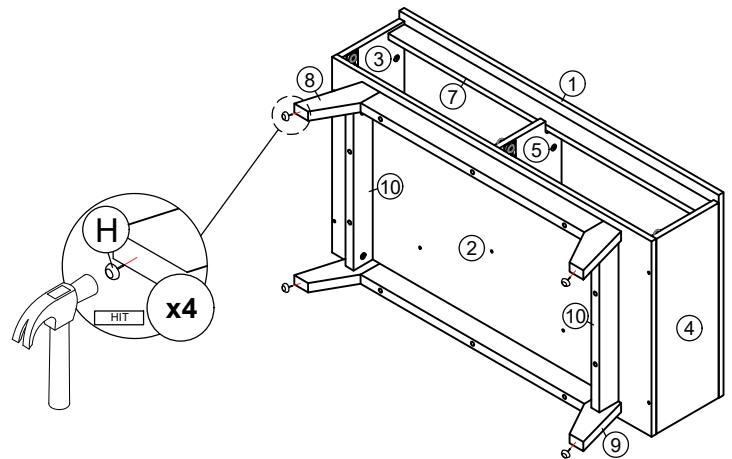

CODING
- 133113

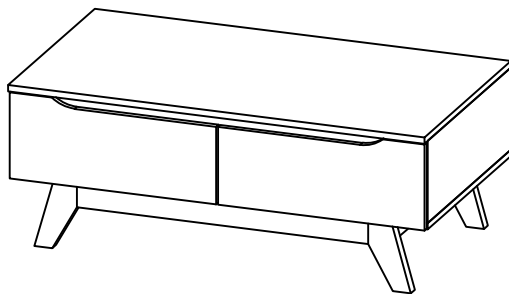

ISO 9001:2015
Reg. No. 000435-1-2017-1-0265

nuhoom.com

STEP 11

Assemble panel (14) to panel (11) or (12) and (13) by using hardware F. (Repeat 16 times.)



STEP 12

Assemble panel (15) to entire body with hardware G. (Repeat 16 times.)

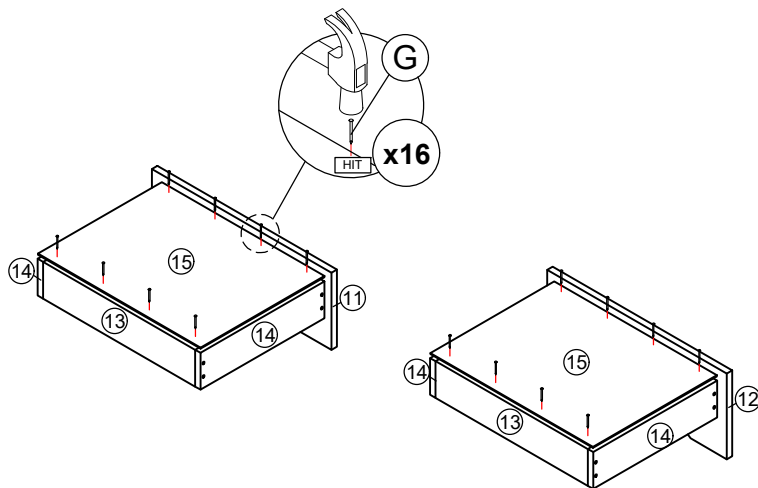
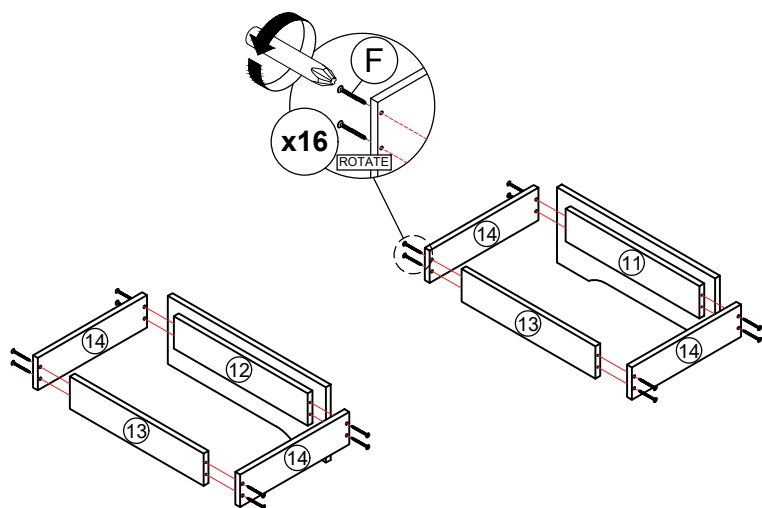

STEP 13

Assemble hardware 12 (L/R) to panel (15) by using hardware E. (Repeat 3 times for each hardware.)



STEP 14

Put all the drawer in place along the drawer slides.

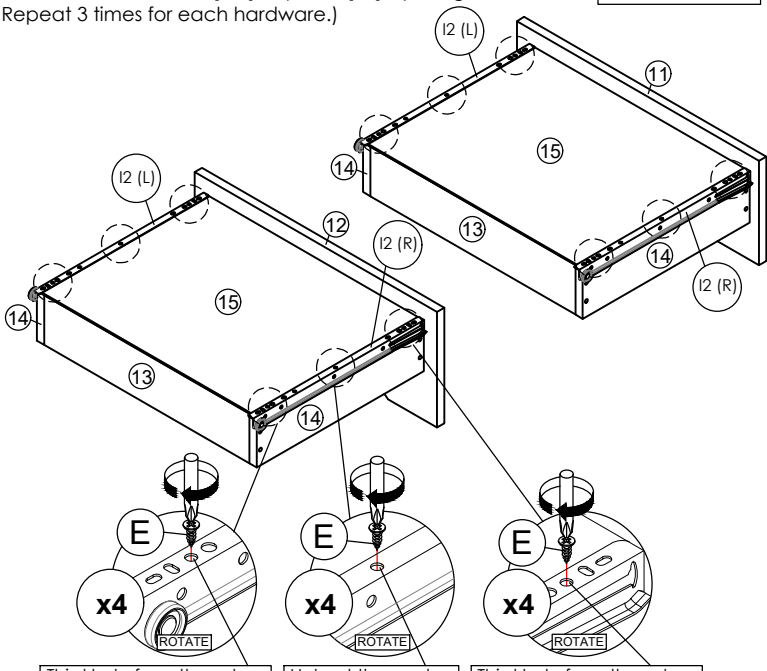

Third hole from the edge. Hole at the center. Third hole from the edge.

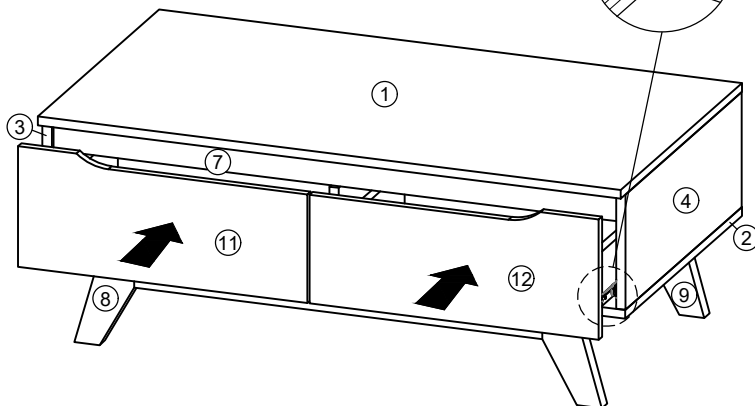
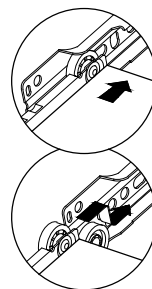

*Hardware 12 (L/R) shall be leaning against panel (11) or (12) when assembling.