

CODING
- 133101

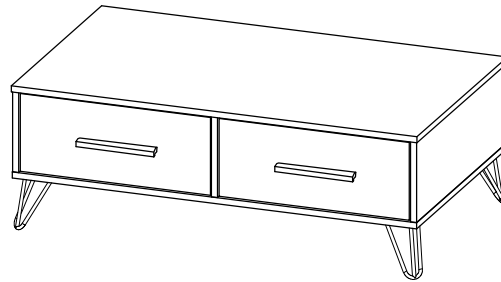

ISO 9001:2015
Reg. No. 000435-1-MY-1-QMS

nuhoom.com

Read the instructions carefully. Remove all the wrappings, staples and straps from the carton. Refer to the hardware and furniture part list for guidance. Make sure that you have all the parts before you start assembling. Place all the wooden furniture parts on a clean, flat and soft surface, such as a carpet or rubbermat to prevent scratches.

CAUTION
KEEP ALL THE PARTS OUT OF CHILDREN'S REACH.

PART LIST		QTY
1	TOP PANEL	1 PC
2	BOTTOM PANEL	1 PC
3	SIDE PANEL (L)	1 PC
4	SIDE PANEL (R)	1 PC
5	CENTER PANEL	1 PC
6	BACK PANEL	1 PC
7	DRAWER FRONT PANEL	2 PCS
8	DRAWER SIDE PANEL	4 PCS
9	DRAWER BACK PANEL	2 PCS
10	DRAWER BOTTOM PANEL	2 PCS

HARDWARE			
A	MINI FIX	A1 A2 A3	10 PCS
B	M8 X 30MM WOOD DOWEL		14 PCS
C	M6 X 50MM CSK CAP WOOD SCREW		8 PCS
D	M4 X 38MM C.B SCREW		16 PCS
E	M3.5 X 16MM C.B SCREW		40 PCS
F	ALLEN KEY M4		1 PC
G	5/8 NAIL		16 PCS
H	14" DRAWER SLIDE	H1 (L/R) H2 (L/R)	2 SETS
I	WOOD HANDLE		2 PCS
J	M4 X 45MM C.B SCREW		6 PCS
K	METAL LEG 90 x 90 x 8 x H145MM		4 PCS

SELF-PREPARED TOOLS: Tools below are NOT included in package.	
SCREWDRIVER	HAMMER

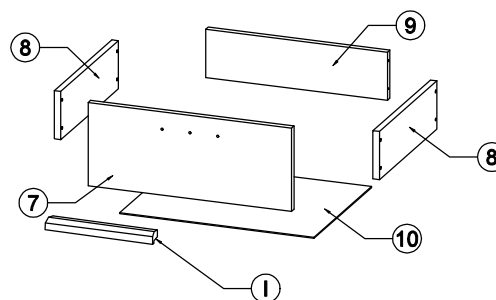
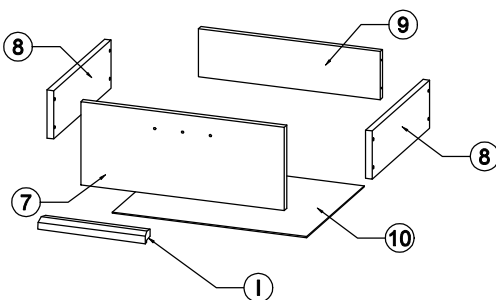
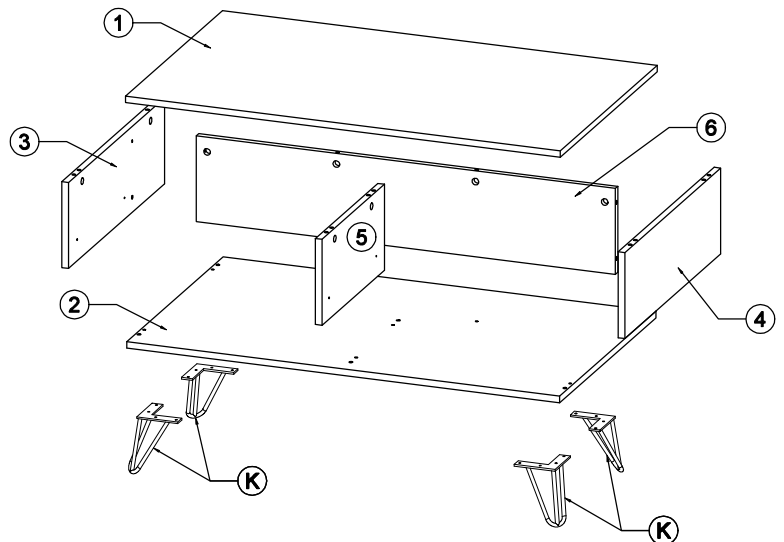

CODING
- 133101

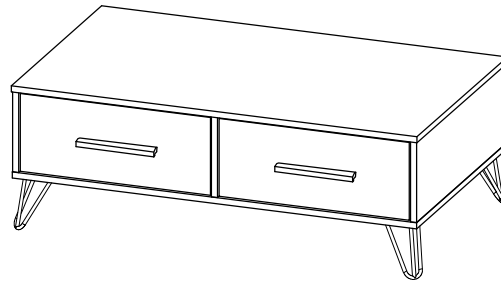

ISO 9001:2015
Reg. No. 00035-1-MY-1-QMS

nuhoom.com

STEP 1

- Insert hardware **A2** onto panel (1).
(Repeat 8 times.)

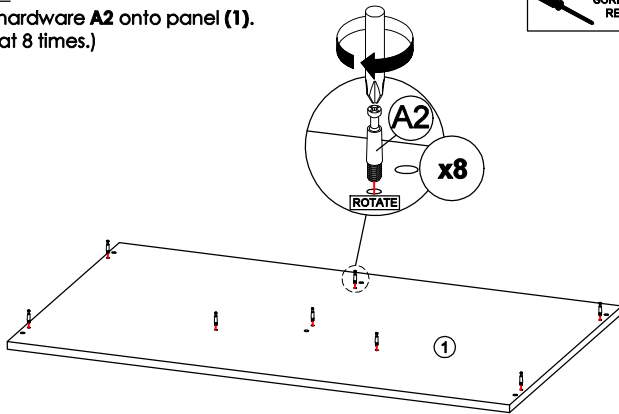

STEP 2

- Insert hardware **A1** onto panel (3) and (4).
(Repeat 4 times.)
- Insert hardware **A2** onto panel (3) and (4).
(Repeat 2 times.)
- Insert hardware **B** onto panel (3) and (4).
(Repeat 8 times.)

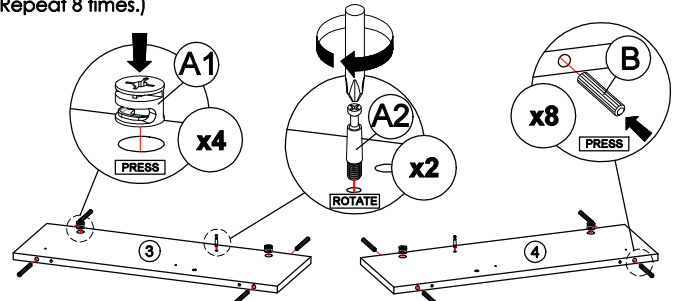

* Ensure the arrows on hardware **A1** point towards mounting positions.

STEP 3

- Insert hardware **A1** onto panel (5).
(Repeat 2 times.)
- Insert hardware **B** onto panel (5).
(Repeat 4 times.)

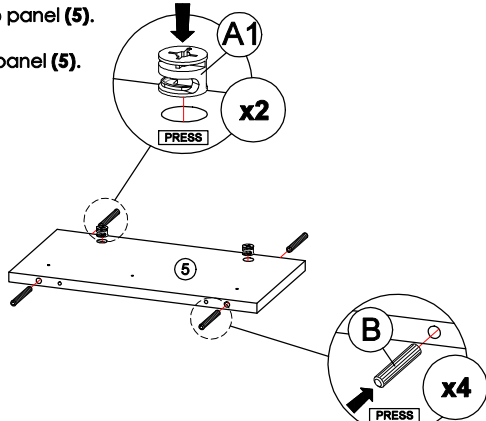

* Ensure the arrows on hardware **A1** point towards mounting positions.

STEP 4

- Fix hardware **H1 (L)** into panel (5) with hardware **E**.
(Repeat 3 times for each hardware.)



STEP 5

- Fix hardware **H1 (R)** into panel (4) and (5) with hardware **E**.
(Repeat 3 times for each hardware.)

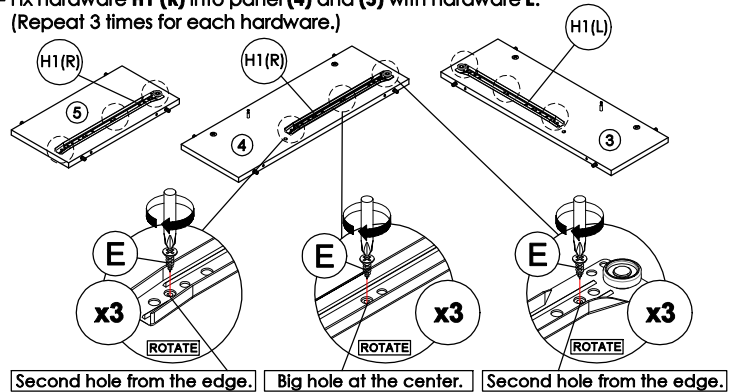

STEP 6

- Fix hardware **H1 (L)** into panel (5) with hardware **E**.
(Repeat 3 times for each hardware.)

STEP 6

- Insert hardware **A1** onto panel (6).
(Repeat 4 times.)
- Insert hardware **B** onto panel (6).
(Repeat 2 times.)

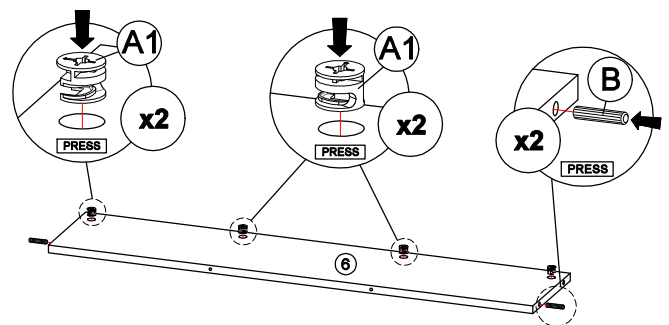

* Ensure the arrows on hardware **A1** point towards mounting positions.

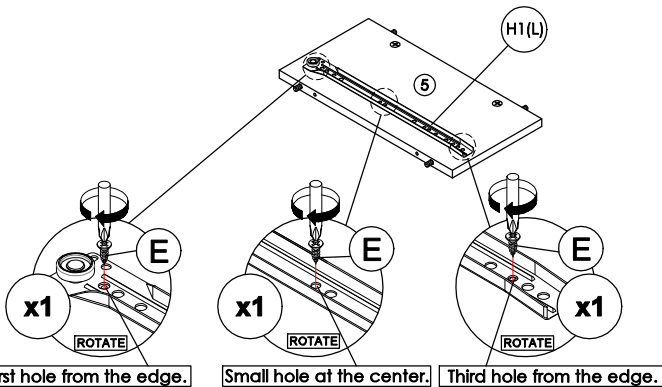

CODING
- 133101

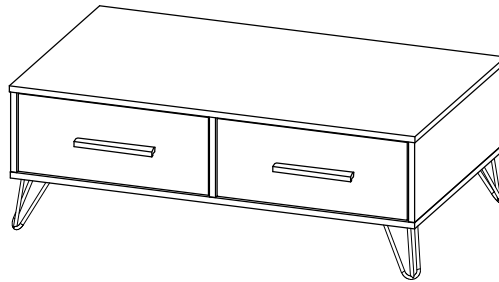

ISO 9001:2015
Reg. No. 000435-1-MY-1-QM

nuhoom.com

STEP 7

- Attach panel (6) to panel (3) and (4).
- Insert all hardware A2 into A1.
- Rotate all A1 until tight.
- Apply A3 onto all A1.
- (Repeat 2 times.)

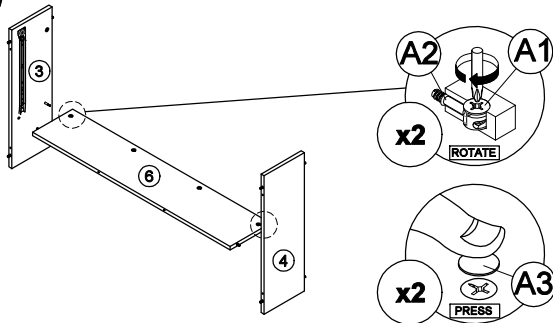
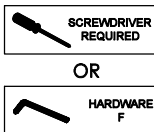

* In this step hardware A1, A2 and B are pre-inserted.

STEP 9

- Attach panel (5) to panel (1).
- Insert all hardware A2 into A1.
- Rotate all A1 until tight.
- Apply A3 onto all A1.
- (Repeat 2 times.)

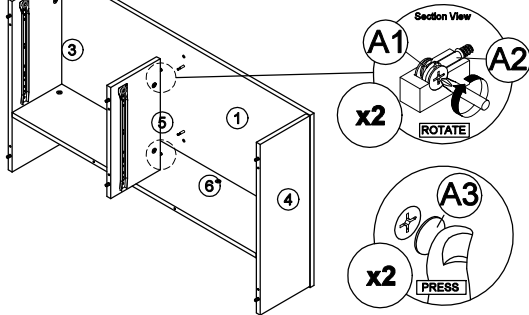
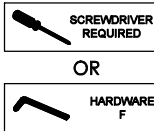

* In this step hardware A1, A2 and B are pre-inserted.

STEP 11

- Assemble hardware K onto panel (2)
- by using hardware E.
- (Repeat 4 times for each hardware.)

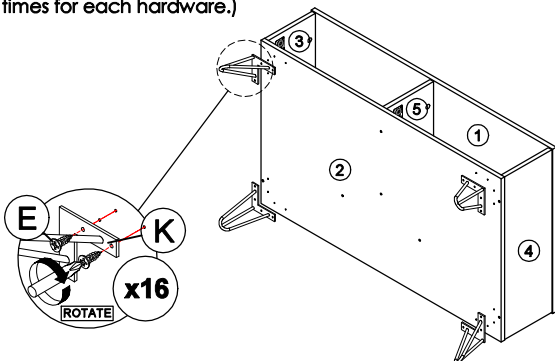

STEP 8

- Attach panel (3), (4) and (6) to panel (1).
- Insert all hardware A2 into A1.
- Rotate all A1 until tight.
- Apply A3 onto all A1.
- (Repeat 6 times.)

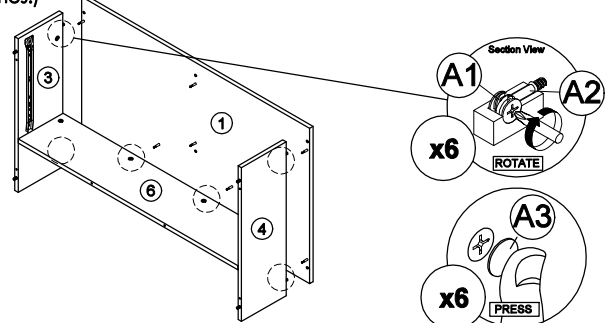
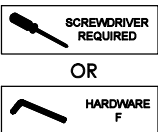

* In this step hardware A1, A2 and B are pre-inserted.

STEP 10

- Connect panel (2) to panel (3), (4), (5) and (6) by using hardware C and F.
- (Repeat 8 times.)

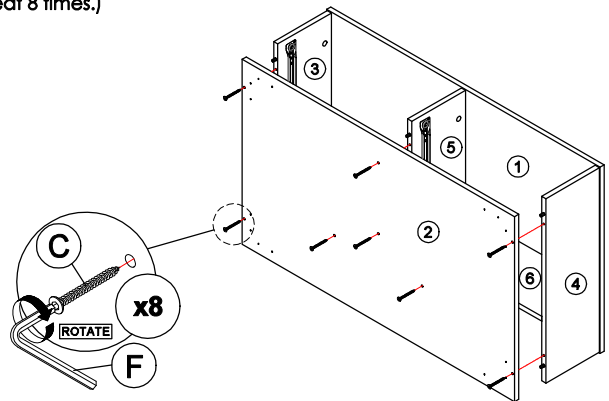
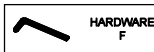

STEP 12

- Assemble panel (8) to panel (7) and (9) by using hardware D.
- (Repeat 16 times.)

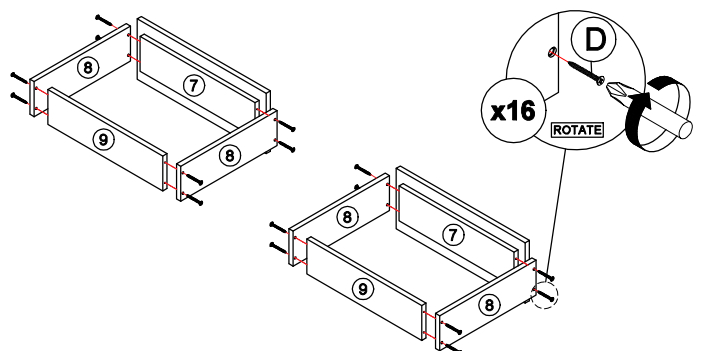

CODING
- 133101

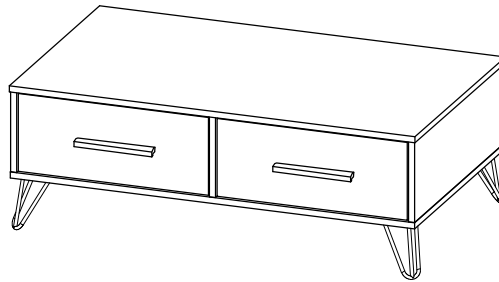

ISO 9001:2015
Reg. No. 000435-1-MY-1-QM

nuhoom.com

STEP 13
Assemble panel (10) to entire body with hardware G.
(Repeat 16 times.)



STEP 14
Assemble hardware H2 (L/R) to panel (10) by using hardware E.
(Repeat 3 times for each hardware.)

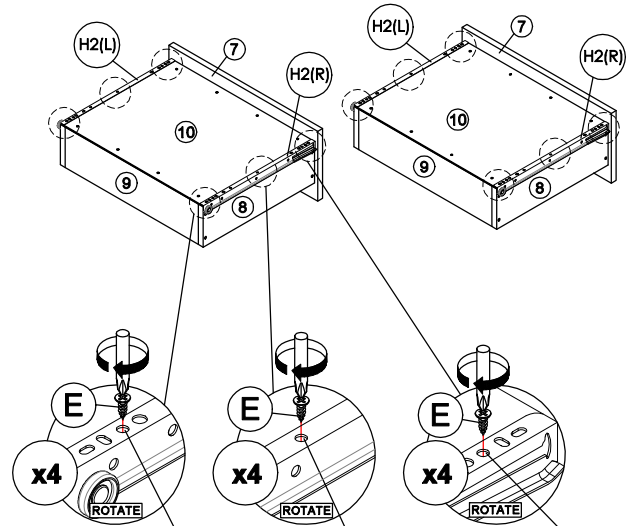
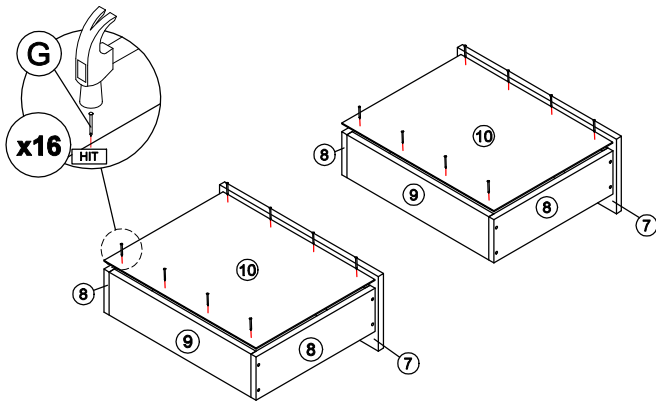

Third hole from the edge. | Hole at the center. | Third hole from the edge.
*Hardware H2 (L/R) shall be leaning against panel (7) when assembling.

STEP 15
Fix hardware I onto panel (7) by using hardware J.
(Repeat 3 times for each hardware.)



STEP 16
Put all the drawer in place along the drawer slides.

