

## CODING

-131122

-131120



ISO 9001:2015  
Reg. No. 00005-1-2017-1-QMS

nuhoom.com

Read the instructions carefully. Remove all the wrappings, staples and straps from the carton. Refer to the hardware and furniture part list for guidance. Make sure that you have all the parts before you start assembling. Place all the wooden furniture parts on a clean, flat and soft surface, such as a carpet or rubbermat to prevent scratches.

**CAUTION**  
KEEP ALL THE PARTS OUT OF CHILDREN'S REACH.

HARDWARE			
A	MINI FIX	A1  A2  A3	10 SETS
B	M8 X 30MM WOOD DOWEL		24 PCS
C	M6 X 50MM CSK CAP WOOD SCREW		6 PCS
D	ALLEN KEY M4		1 PC
E	M3.5 X 16MM C.B SCREW		24 PCS
F	M4 X 38MM C.B SCREW		24 PCS
G	5/8 NAIL		16 PCS
H	5/8 PVC NAIL LEG		4 PCS
I	14" DRAWER SLIDE	I1 (L/R) I2 (L/R)	2 SETS

**SELF-PREPARED TOOLS:** Tools below are NOT included in package.

	SCREWDRIVER		HAMMER
--	-------------	--	--------

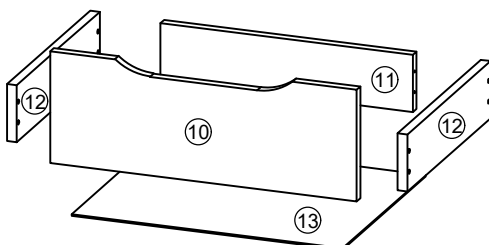
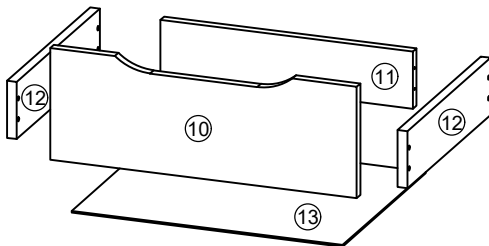

PART LIST		QTY
1	TOP PANEL	1 PC
2	BOTTOM PANEL	1 PC
3	SIDE PANEL (L)	1 PC
4	SIDE PANEL (R)	1 PC
5	BONE PANEL	2 PCS
6	BACK PANEL	1 PC
7	APRON BONE (FRONT)	1 PC
8	APRON BONE (BACK)	1 PC
9	APRON BONE	2 PCS
10	DRAWER FRONT	2 PCS
11	DRAWER BACK	2 PCS
12	DRAWER SIDE	4 PCS
13	DRAWER BOTTOM	2 PCS

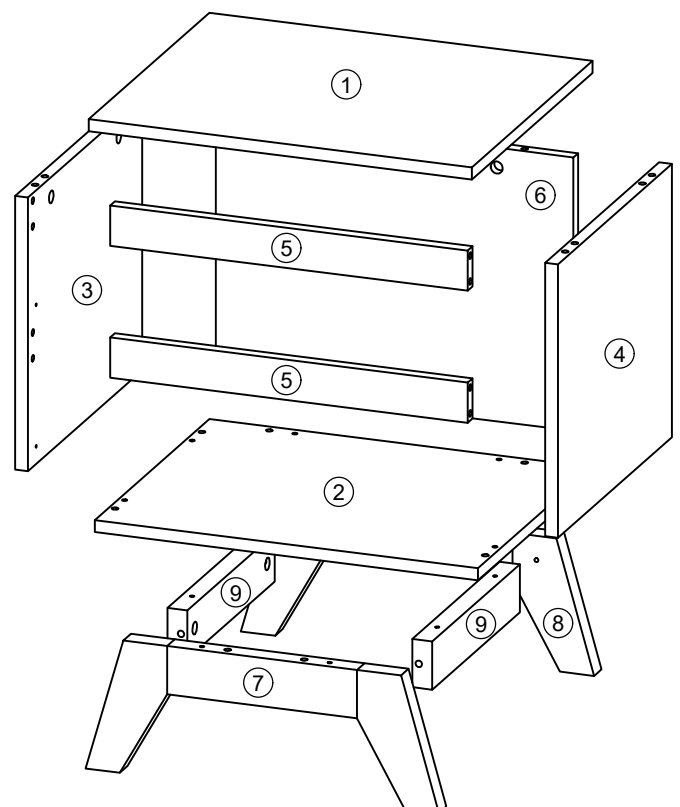

**CODING**  
- 131120

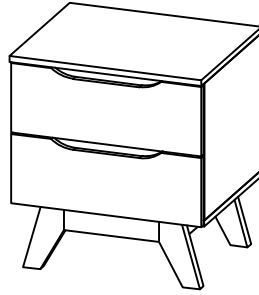

ISO 9001:2015  
Reg. No. 000435-1-MFF-1-QMS

nuhoom.com

### STEP 1

- Insert hardware **A1** onto panel (3), (4) and (6).  
(Repeat 6 times.)
- Insert hardware **A2** onto panel (1).  
(Repeat 6 times.)
- Insert hardware **B** onto panel (3), (4) and (6).  
(Repeat 12 times.)

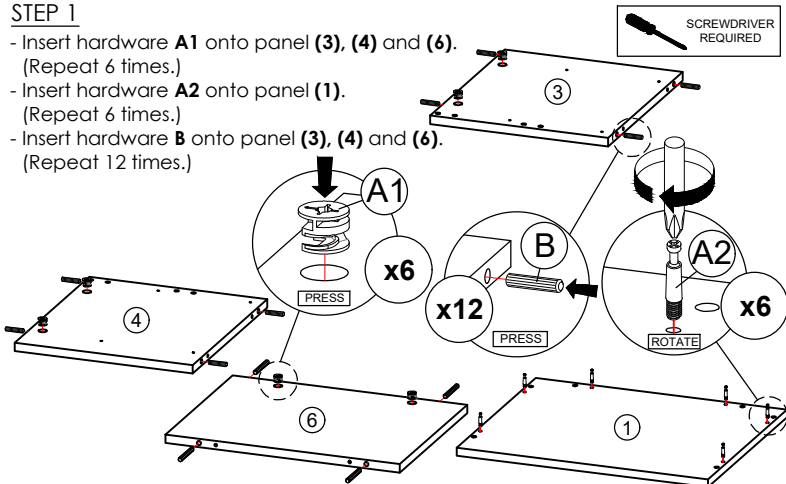

\* Ensure the arrows on hardware **A1** point towards mounting positions.

### STEP 2

- Insert hardware **A1** onto panel (9).  
(Repeat 4 times.)
- Insert hardware **A2** onto panel (7) and (8).  
(Repeat 4 times.)
- Insert hardware **B** onto panel (5), (7) and (8).  
(Repeat 12 times.)

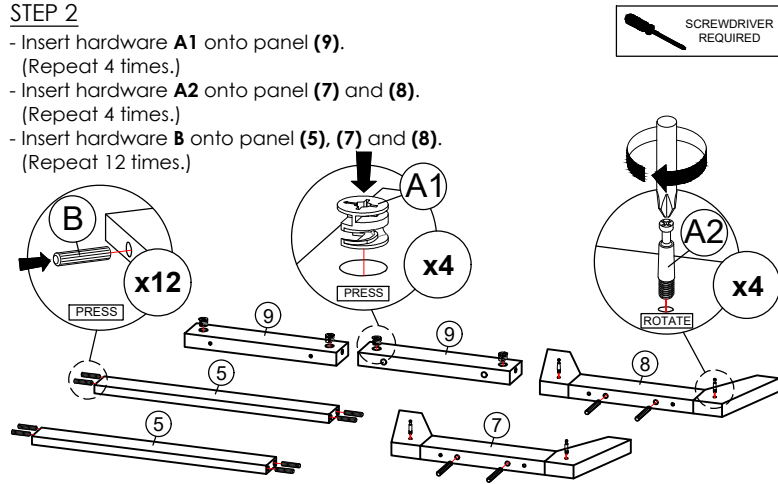

\* Ensure the arrows on hardware **A1** point towards mounting positions.

### STEP 3

- Fix hardware **I1 (L/R)** into panel (3) and (4) with hardware **E**.  
(Repeat 3 times for each hardware.)

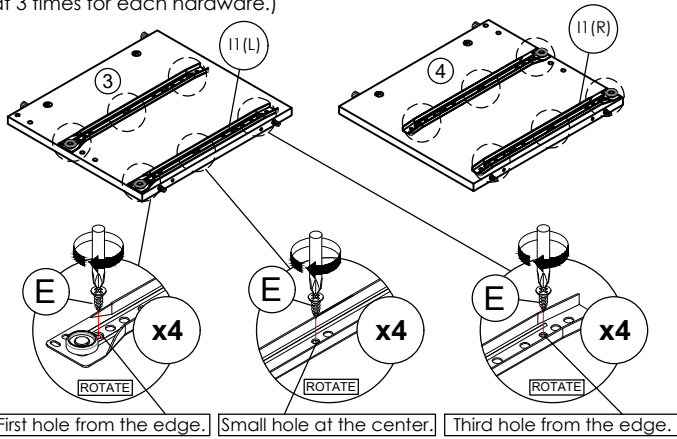

### STEP 4

- Attach panel (3) and (4) to panel (5).  
(Repeat 2 times.)

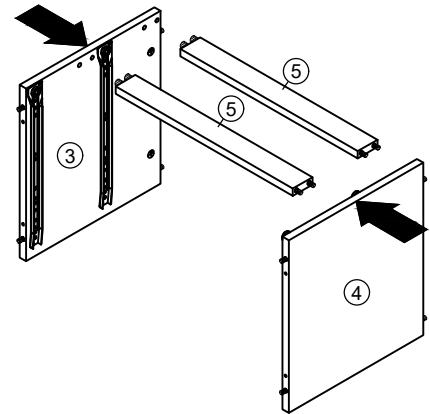

\* In this step hardware **B** are pre-inserted.

### STEP 5

- Attach panel (1) to panel (3), (4) and (6).
- Insert all hardware **A2** into **A1**.
- Rotate all **A1** until tight.
- Apply **A3** onto all **A1**.  
(Repeat 6 times.)



OR

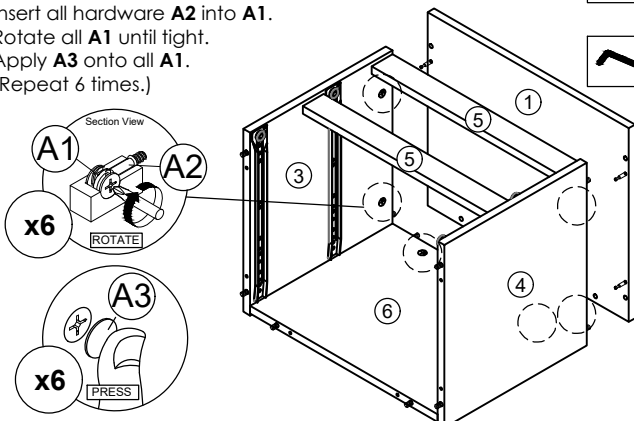
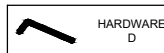

\* In this step hardware **A1**, **A2** and **B** are pre-inserted.

### STEP 6

- Connect panel (2) to panel (3), (4) and (6) by using hardware **C** and **D**.  
(Repeat 6 times.)

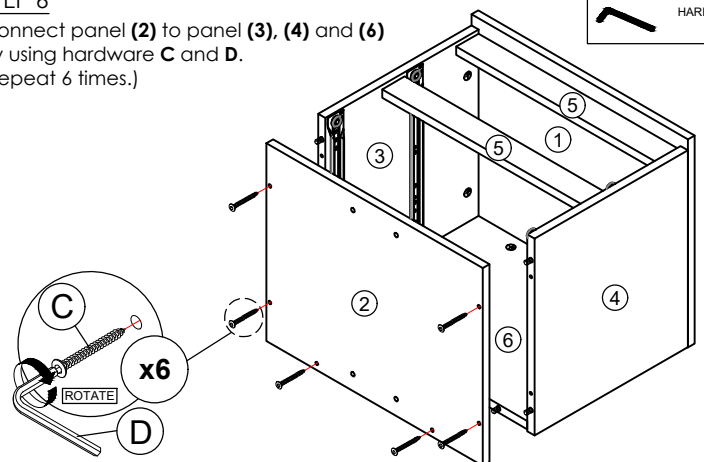

\* In this step hardware **B** are pre-inserted.

**CODING**  
- 131120



ISO 9001:2015  
Reg. No. 000435-1-MTF-1-QMS

nuhoom.com

**STEP 7**

- Attach panel (7) and (8) to panel (9).
- Insert all hardware A2 into A1.
- Rotate all A1 until tight.
- Apply A3 onto all A1.
- (Repeat 4 times.)

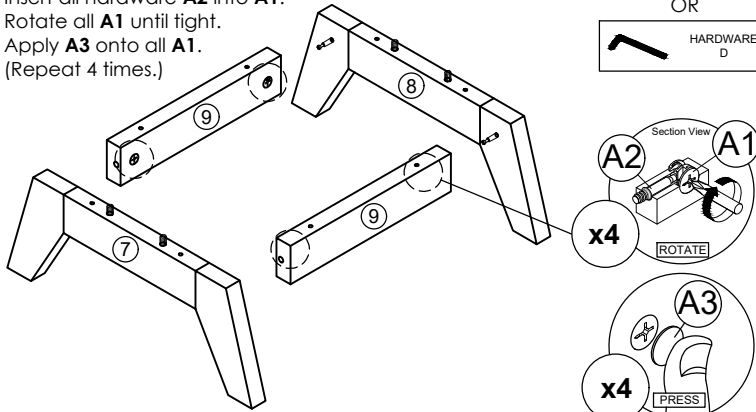
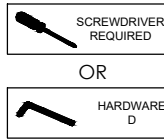

\* In this step hardware A1, A2 and B are pre-inserted.

**STEP 9**

- Assemble panel (12) to panel (10) and (11) by using hardware F.
- (Repeat 16 times.)

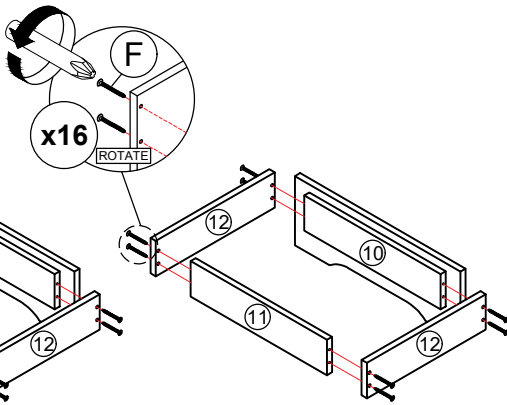

**STEP 11**

- Assemble hardware 12 (L/R) to panel (13) by using hardware E.
- (Repeat 3 times for each hardware.)

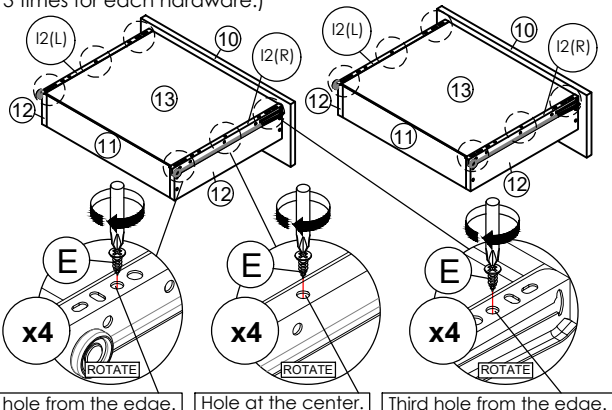

Third hole from the edge. | Hole at the center. | Third hole from the edge.

\*Hardware 12 (L/R) shall be leaning against panel (10) when assembling.

**STEP 8**

- Hit hardware H into bottom of panel (7) and (8).
- (Repeat 4 times.)
- Assemble panel (7), (8) and (9) with panel (2) by using hardware F.
- (Repeat 8 times.)

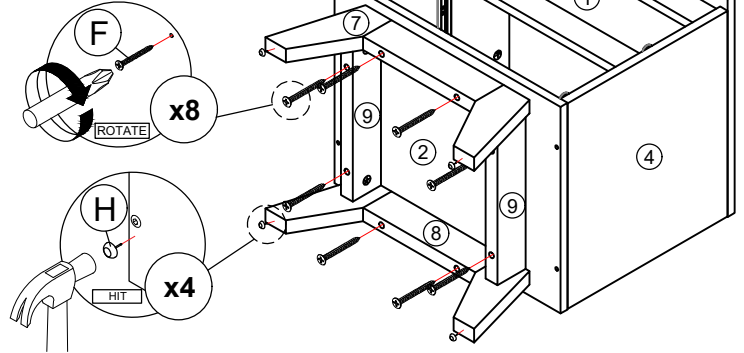

**STEP 10**

- Assemble panel (13) to entire body with hardware G.
- (Repeat 16 times.)

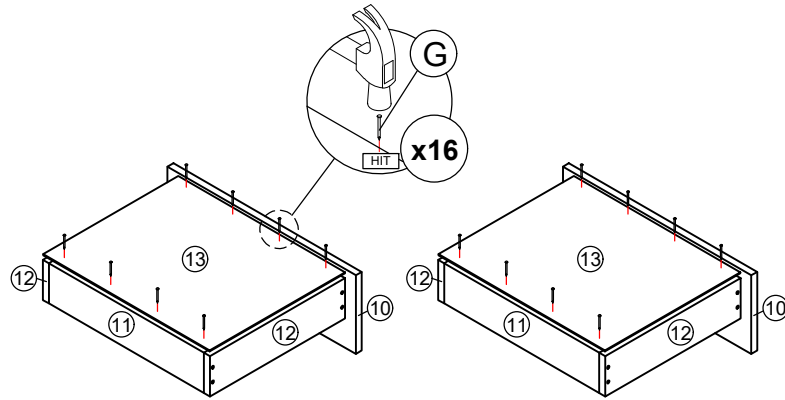

**STEP 12**

- Put all the drawer in place along the drawer slides.

