

CODING
- 131098

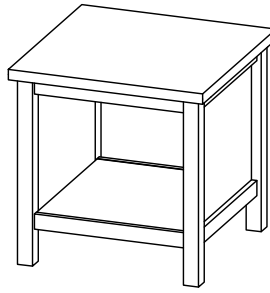







ISO 9001:2015
Reg. No. 00005-1-MF-1-QMS

nuhoom.com

Read the instructions carefully. Remove all the wrappings , staples and straps from the carton. Refer to the hardware and furniture part list for guidance. Make sure that you have all the parts before you start assembling. Place all the wooden furniture parts on a clean, flat and soft surface, such as a carpet or rubbermat to prevent scratches.

CAUTION
KEEP ALL THE PARTS OUT OF CHILDREN'S REACH.

PART LIST		QTY
1	TOP PANEL	1 PC
2	BOTTOM PANEL	1 PC
3	SIDE PANEL	2 PCS
4	RAIL TOP	2 PCS
5	RAIL BOTTOM	2 PCS

HARDWARE			
A	MINI FIX	A1  A2  A3 	16 SETS
B	M8 X 30MM WOOD DOWEL		16 PCS
C	M8 X 40MM WOOD DOWEL		16 PCS
D	ALLEN KEY M4		1 PC
E	5/8 PVC NAIL LEG		4 PCS

SELF-PREPARED TOOLS: Tools below are NOT included in package.

	SCREWDRIVER		HAMMER
---	-------------	---	--------

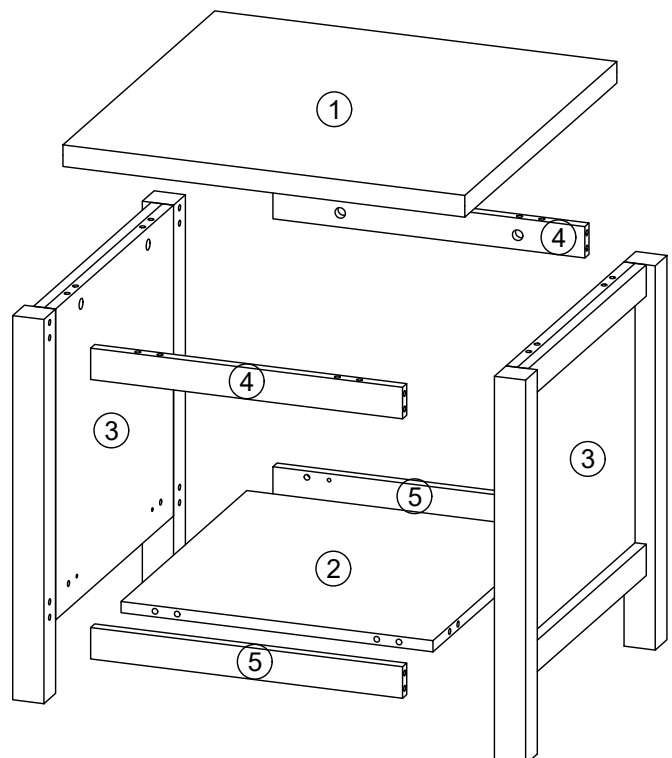

CODING
- 131098

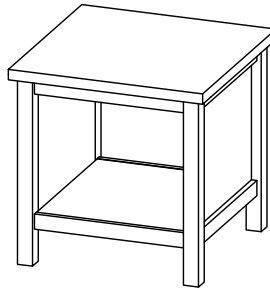

ISO 9001:2015
Reg. No. 00005-1-MTF-1-QMS

nuhoom.com

STEP 1

- Insert hardware **A2** onto panel (1) and (5).
(Repeat 12 times.)
- Insert hardware **C** onto panel (5).
(Repeat 8 times.)



STEP 2

- Insert hardware **A1** onto panel (2).
(Repeat 8 times.)
- Insert hardware **B** onto panel (2).
(Repeat 8 times.)

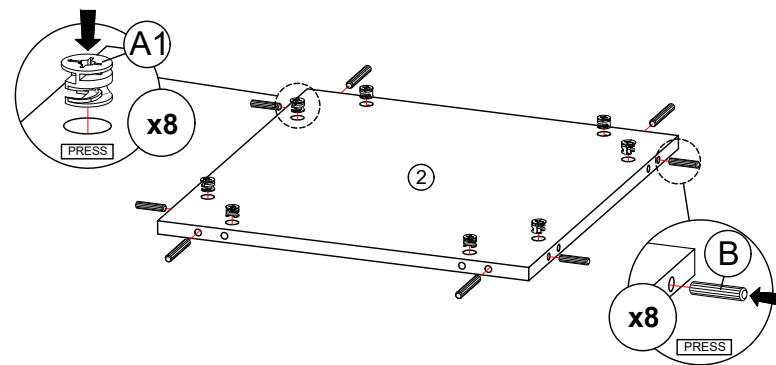
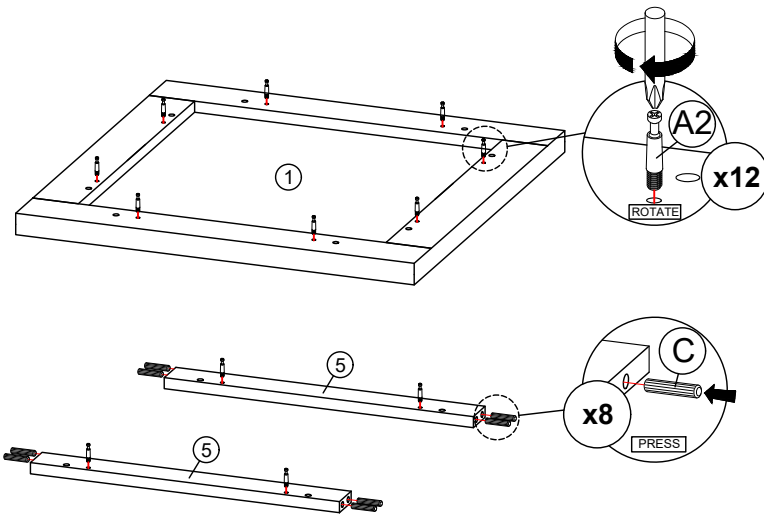

STEP 3

- Insert hardware **A1** onto panel (4).
(Repeat 4 times.)
- Insert hardware **B** onto panel (4).
(Repeat 4 times.)
- Insert hardware **C** onto panel (4).
(Repeat 8 times.)



STEP 4

- Insert hardware **A1** onto panel (3).
(Repeat 4 times.)
- Insert hardware **A2** onto panel (3).
(Repeat 4 times.)
- Insert hardware **B** onto panel (3).
(Repeat 4 times.)

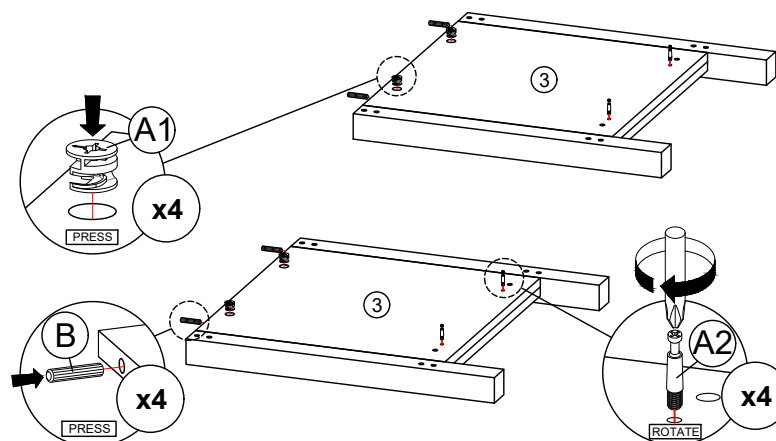
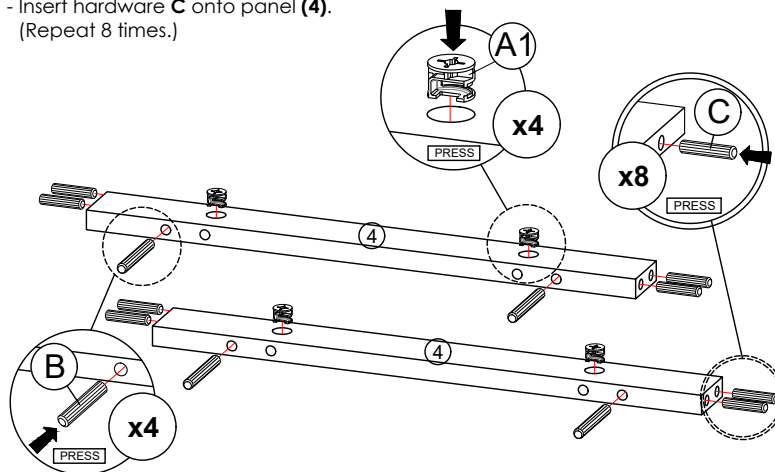

* Ensure the arrows on hardware **A1** point towards mounting positions.

* Ensure the arrows on hardware **A1** point towards mounting positions.

CODING
- 131098

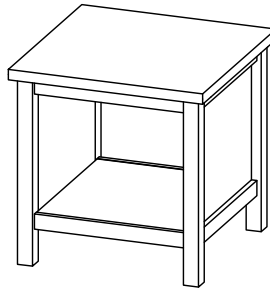

ISO 9001:2015
Reg. No. 009-05-1-MF-1-QMS

nuhoom.com

STEP 5

- Attach panel (5) to panel (2).
- Insert all hardware A2 into A1.
- Rotate all A1 until tight.
- Apply A3 onto all A1.
- (Repeat 4 times.)

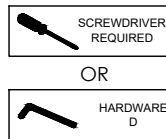

STEP 6

- Attach panel (3) to panel (2), (4) and (5).
- Insert all hardware A2 into A1.
- Rotate all A1 until tight.
- Apply A3 onto all A1.
- (Repeat 4 times.)

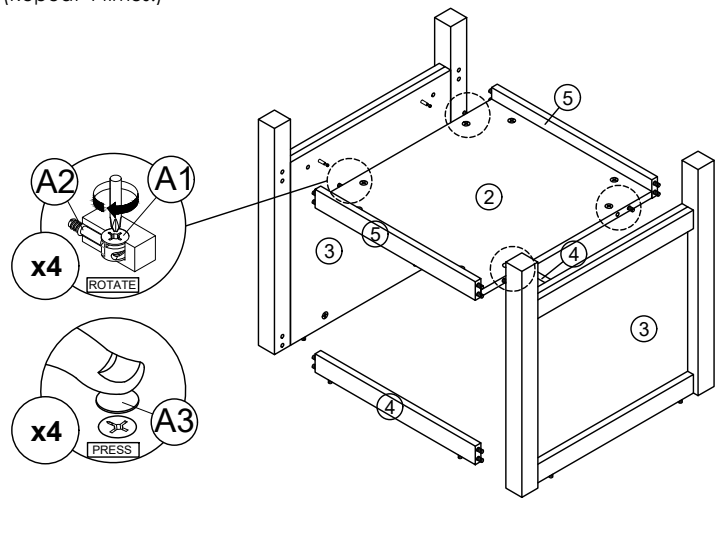
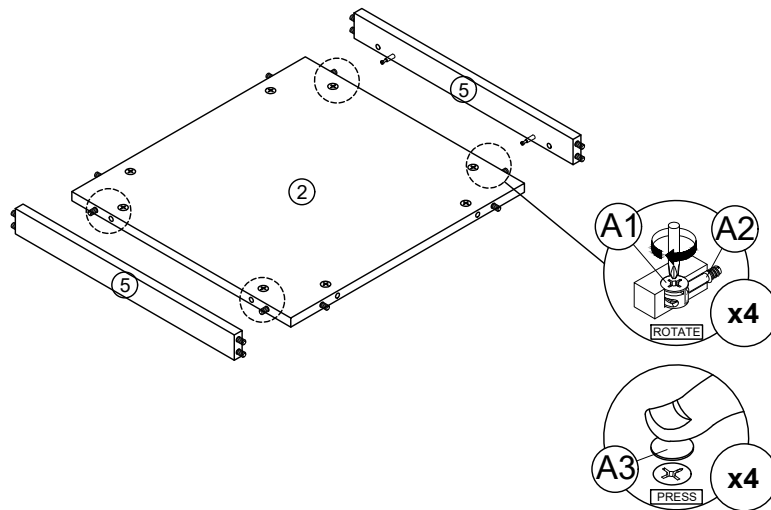
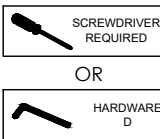

* In this step hardware A1, A2 and B are pre-inserted.

* In this step hardware A1, A2 and B are pre-inserted.

STEP 7

- Attach panel (1) to panel (3) and (4).
- Insert all hardware A2 into A1.
- Rotate all A1 until tight.
- Apply A3 onto all A1.
- (Repeat 8 times.)

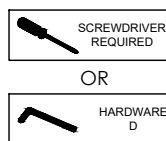

STEP 8

- Hit hardware E into bottom of panel (3).
- (Repeat 4 times.)

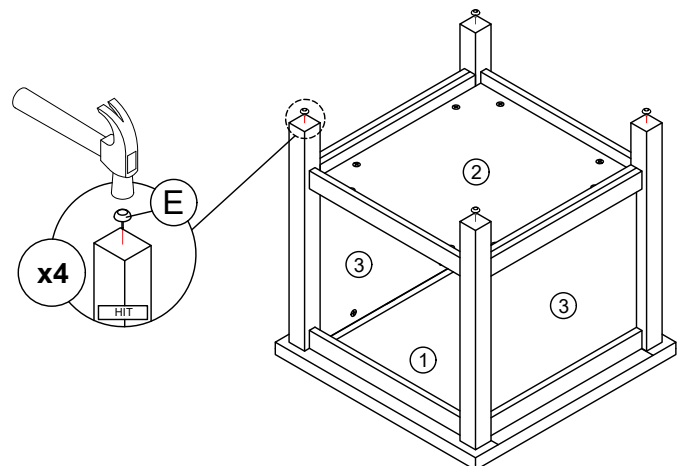
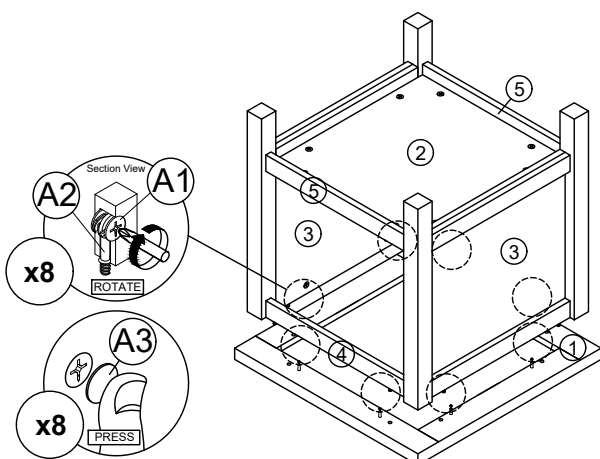

* In this step hardware A1, A2 and B are pre-inserted.