

**CODING**  
- 124070

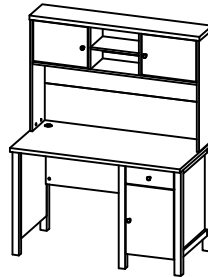













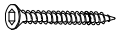



ISO 9001:2015  
Reg. No. 00705-1-REV-1-QMS

**nuhoom.com**

Read the instructions carefully. Remove all the wrappings , staples and straps from the carton. Refer to the hardware and furniture part list for guidance. Make sure that you have all the parts before you start assembling. Place all the wooden furniture parts on a clean, flat and soft surface, such as a carpet or rubbermat to prevent scratches.

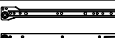
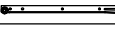
**CAUTION**  
KEEP ALL THE PARTS OUT OF CHILDREN'S REACH.

HARDWARE			
A	MINI FIX	A1  A2  A3 	37 SETS
B	M8 X 30MM WOOD DOWEL		40 PCS
C	M6 X 50MM CSK CAP WOOD SCREW		4 PCS
D	ALLEN KEY M4		1 PC
E	M3.5 X 16MM C.B SCREW		48 PCS
F	M4 X 25MM C.B SCREW		4 PCS
G	M4 X 38MM C.B SCREW		4 PCS
H	5/8 NAIL		39 PCS
I	5/8 PVC NAIL LEG		6 PCS
J	METAL SHELF SUPPORT		4 PCS
K	SOFT CLOSING 7/8 HINGES		6 PCS
L	WIRE CAP ( 35MM )		1 PC
M	311 KNOD ( GOLDEN 3106 )		4 PCS
N	14" DRAWER SLIDE	 N1 ( L/R )  N2 ( L/R )	1 PC
O	STOPPER(2 PIN)		2 PCS

**SELF-PREPARED TOOLS:** Tools below are NOT included in package.



SCREWDRIVER



HAMMER

PART LIST		QTY
1	UP TOP PANEL	1 PC
2	UP MIDDLE PANEL	1 PC
3	UP SIDE PANEL - L	1 PC
4	UP SIDE PANEL - R	1 PC
5	UP CENTER PANEL - L	1 PC
6	UP CENTER PANEL - R	1 PC
7	UP MIDDLE SMALL	1 PC
8	UP BACK PANEL	1 PC
9	UP DOOR PANEL - L&R	2 PCS
10	TOP PANEL	1 PC
11	BOTTOM PANEL	1 PC
12	SIDE PANEL - L	1 PC
13	SIDE PANEL - R	1 PC
14	CENTER PANEL	1 PC
15	SHELF PANEL	1 PC
16	BACK PANEL	1 PC
17	BACK BOARD	1 PC
18	DOOR PANEL	1 PC
19	DRAWER FRONT	1 PC
20	DRAWER BACK	1 PC
21	DRAWER SIDE - L	1 PC
22	DRAWER SIDE - R	1 PC
23	DRAWER BOTTOM	1 PC

CODING  
- 124070

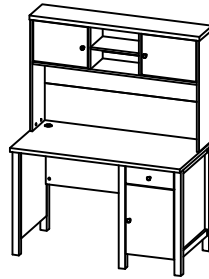

ISO 9001:2015  
Reg. No. 007-05-1-ACEY-1-008

nuhoom.com

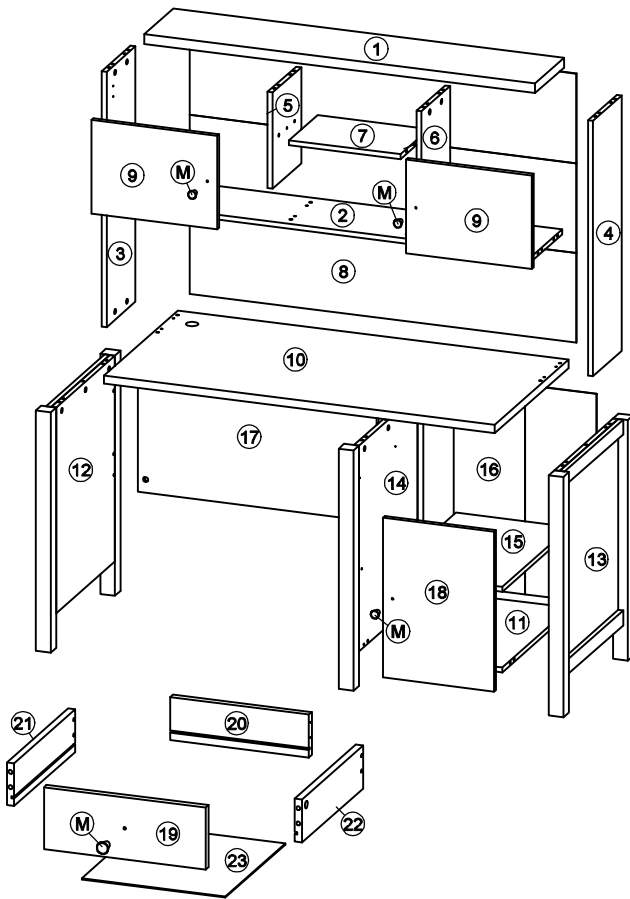

### STEP 1

- Insert hardware **A1** onto panel **(2)**.  
(Repeat 4 times.)
- Insert hardware **A2** onto panel **(1)**.  
(Repeat 8 times.)
- Insert hardware **B** onto panel **(2)**.  
(Repeat 4 times.)
- Hit hardware **O** onto panel **(1)**.  
(Repeat 2 times.)

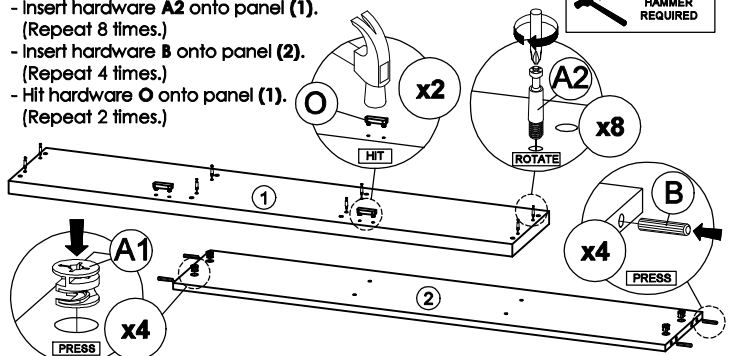
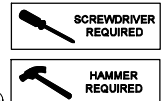

\* Ensure the arrows on hardware **A1** point towards mounting positions.

### STEP 2

- Insert hardware **A1** onto panel **(3)**, **(4)** and **(5)**.  
(Repeat 10 times.)
- Insert hardware **A2** onto panel **(3)**, **(4)** and **(5)**.  
(Repeat 5 times.)
- Insert hardware **B** onto panel **(3)**, **(4)** and **(5)**.  
(Repeat 12 times.)

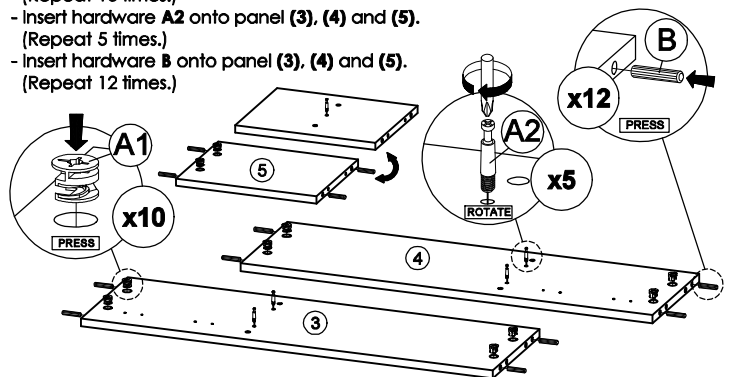

\* Ensure the arrows on hardware **A1** point towards mounting positions.

### STEP 3

- Insert hardware **A1** onto panel **(6)** and **(7)**.  
(Repeat 4 times.)
- Insert hardware **A2** onto panel **(6)** and **(10)**.  
(Repeat 14 times.)
- Insert hardware **B** onto panel **(6)** and **(7)**.  
(Repeat 8 times.)

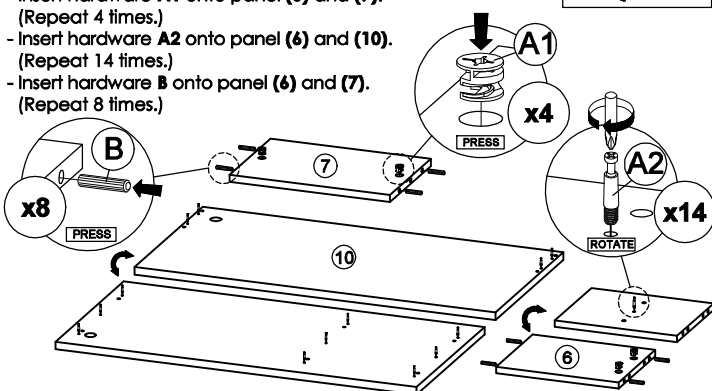

\* Ensure the arrows on hardware **A1** point towards mounting positions.

### STEP 4

- Insert hardware **A1** onto panel **(11)**, **(12)** and **(13)**.  
(Repeat 10 times.)
- Insert hardware **A2** onto panel **(12)** and **(13)**.  
(Repeat 4 times.)
- Insert hardware **B** onto panel **(11)**, **(12)** and **(13)**.  
(Repeat 8 times.)

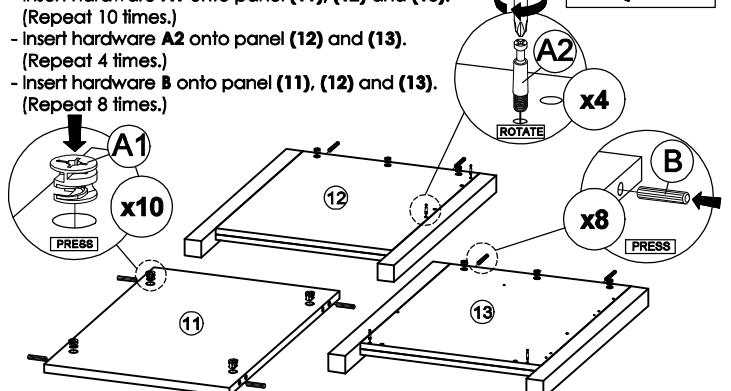

\* Ensure the arrows on hardware **A1** point towards mounting positions.

CODING  
- 124070

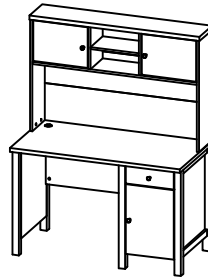

ISO 9001:2015  
Reg. No. 007-05-1-ACE-1-008

nuhoom.com

### STEP 5

- Insert hardware **A1** onto panel (14) and (17).  
(Repeat 7 times.)
- Insert hardware **A2** onto panel (14).  
(Repeat 4 times.)
- Insert hardware **B** onto panel (14) and (17).  
(Repeat 6 times.)

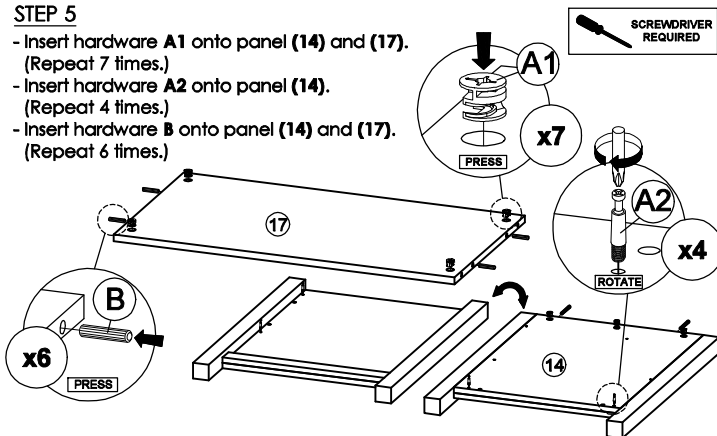

\* Ensure the arrows on hardware **A1** point towards mounting positions.

### STEP 7

- Fix hardware **N1 (L/R)** into panel (13) and (14) with hardware **E**.  
(Repeat 3 times for each hardware.)

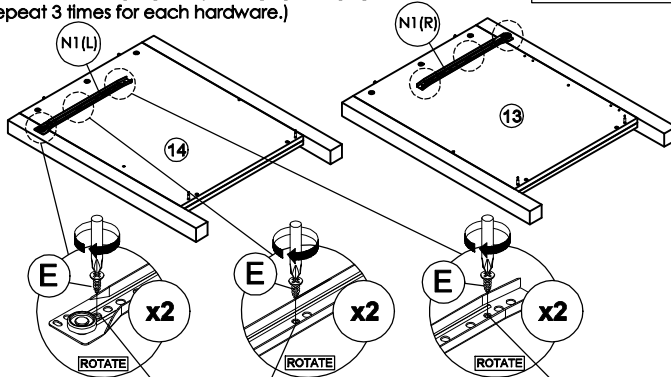

First hole from the edge. Small hole at the center. Third hole from the edge.

### STEP 9

- Connect panel (2) to panel (5) and (6) by using hardware **C** and **D**.  
(Repeat 4 times.)

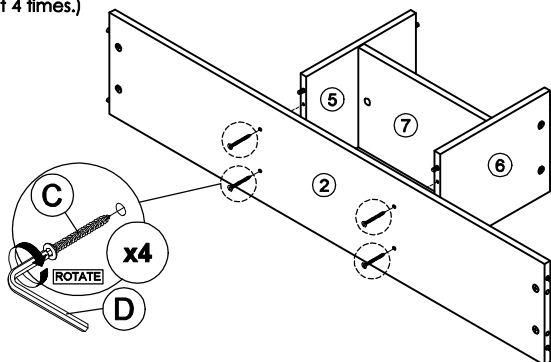

\* In this step hardware **B** are pre-inserted.

### STEP 6

- Insert hardware **A1** onto panel (21) and (22).  
(Repeat 2 times.)
- Insert hardware **A2** onto panel (19).  
(Repeat 2 times.)
- Insert hardware **B** onto panel (21) and (22).  
(Repeat 2 times.)

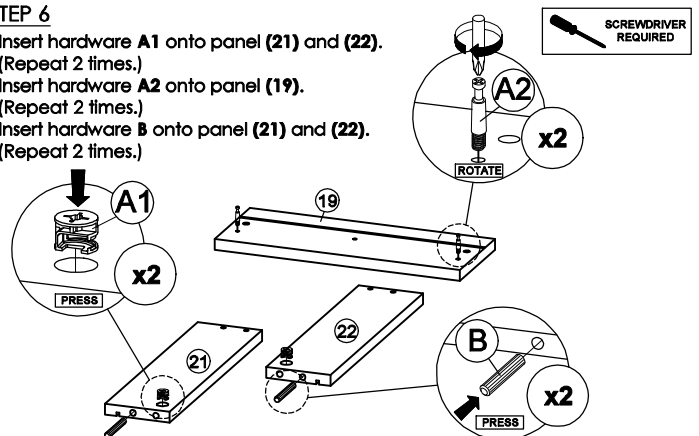

\* Ensure the arrows on hardware **A1** point towards mounting positions.

### STEP 8

- Attach panel (7) to panel (5) and (6).
- Insert all hardware **A2** into **A1**.
- Rotate all **A1** until tight.
- Apply **A3** onto all **A1**.  
(Repeat 2 times.)

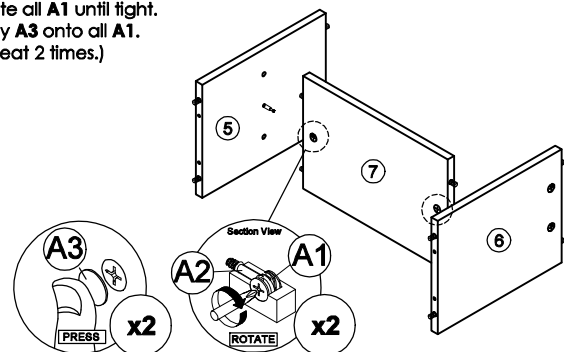

\* In this step hardware **A1**, **A2** and **B** are pre-inserted.

### STEP 10

- Attach panel (2) to panel (3) and (4).
- Insert all hardware **A2** into **A1**.
- Rotate all **A1** until tight.
- Apply **A3** onto all **A1**.  
(Repeat 4 times.)

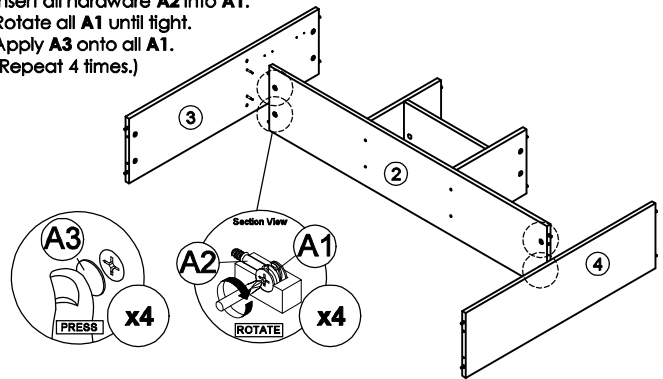

\* In this step hardware **A1**, **A2** and **B** are pre-inserted.

**CODING**  
- 124070

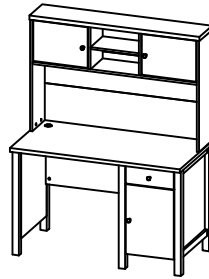

ISO 9001:2015  
Reg. No. 007-05-1-3-ET-1-0-05

nuhoom.com

**STEP 11**

- Attach panel (1) to panel (3), (4), (5) and (6).
- Insert all hardware A2 into A1.
- Rotate all A1 until tight.
- Apply A3 onto all A1.
- (Repeat 8 times.)

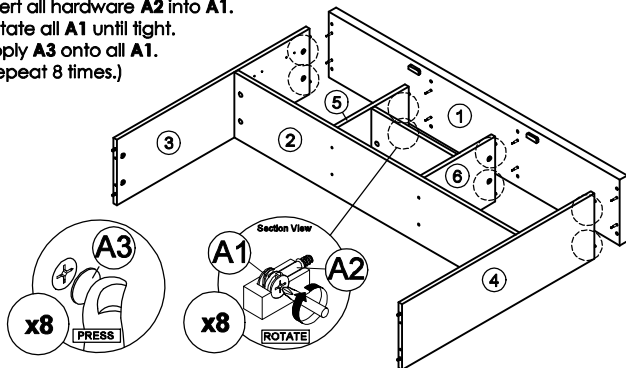

\* In this step hardware A1, A2 and B are pre-inserted.

**STEP 13**

- Attach panel (17) to panel (12) and (14).
- Insert all hardware A2 into A1.
- Rotate all A1 until tight.
- Apply A3 onto all A1.
- (Repeat 4 times.)

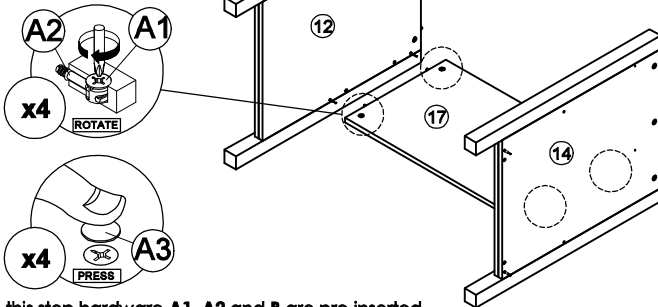

\* In this step hardware A1, A2 and B are pre-inserted.

**STEP 15**

- Attach panel (13) to panel (11).
- Insert all hardware A2 into A1.
- Rotate all A1 until tight.
- Apply A3 onto all A1.
- (Repeat 2 times.)

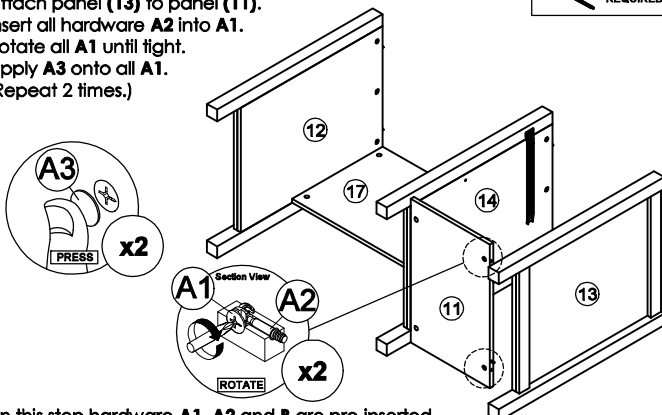

\* In this step hardware A1, A2 and B are pre-inserted.

**STEP 12**

- Attach panel (10) to panel (3) and (4).
- Insert all hardware A2 into A1.
- Rotate all A1 until tight.
- Apply A3 onto all A1.
- (Repeat 4 times.)

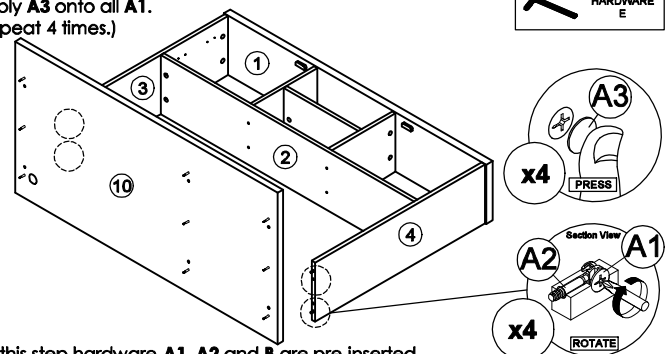
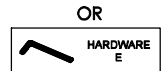

\* In this step hardware A1, A2 and B are pre-inserted.

**STEP 14**

- Attach panel (11) to panel (14).
- Insert all hardware A2 into A1.
- Rotate all A1 until tight.
- Apply A3 onto all A1.
- (Repeat 2 times.)

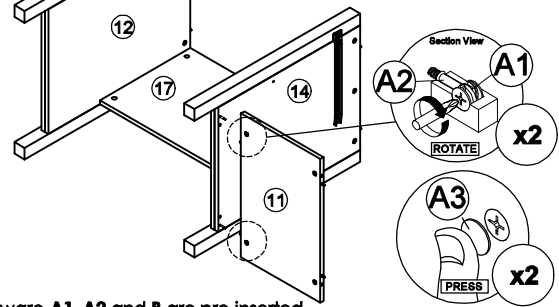

\* In this step hardware A1, A2 and B are pre-inserted.

**STEP 16**

- Attach panel (10) to panel (12), (13) and (14).
- Insert all hardware A2 into A1.
- Rotate all A1 until tight.
- Apply A3 onto all A1.
- (Repeat 9 times.)

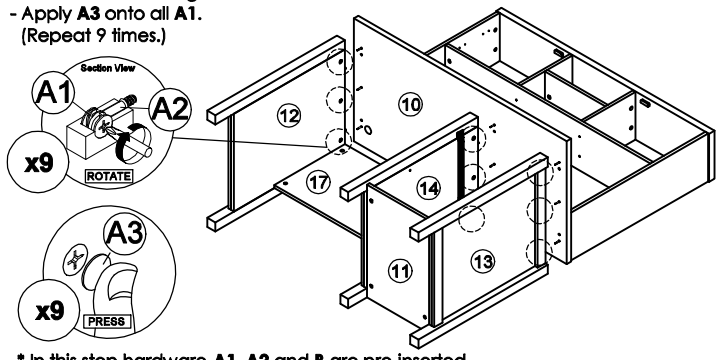

\* In this step hardware A1, A2 and B are pre-inserted.

CODING  
- 124070

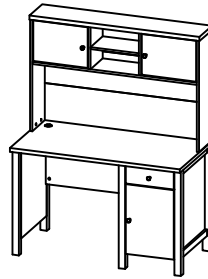

ISO 9001:2015  
Reg. No. 00705-1-ACEY-1-000

nuhoom.com

**STEP 17**

Hit hardware I into bottom of panel (11), (12) and (13).  
(Repeat 6 times.)

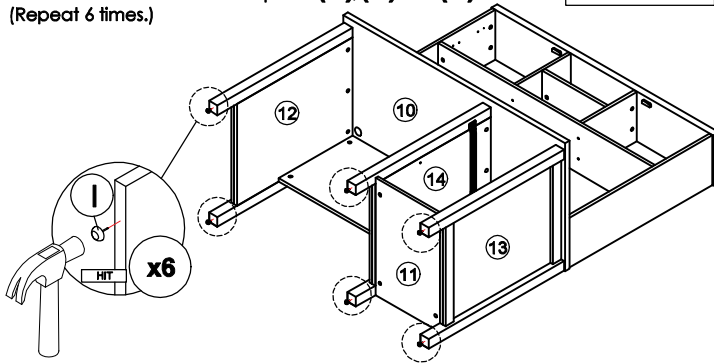

**STEP 18**

Assemble panel (8) and (16) to entire body with hardware H.  
(Repeat 39 times.)

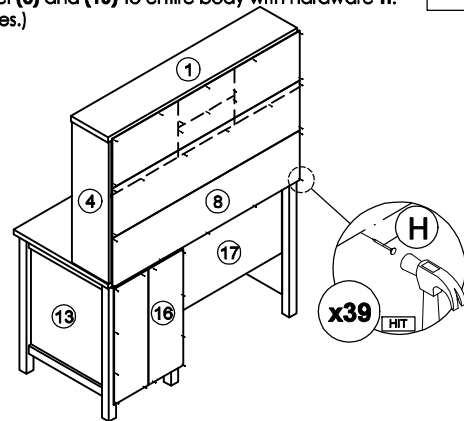

**STEP 19**

- Insert hardware J into mounting positions on panel (13) and (14) by hand.  
(Repeat 4 times.)  
- Assemble the panel (15) into between panel (13) and (14).  
(Repeat 1 times.)

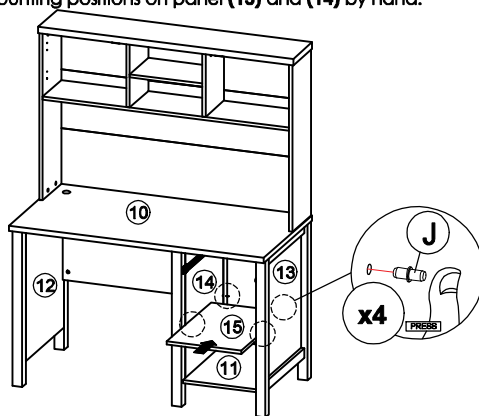

**STEP 20**

Fix hardware M onto panel (19) by using hardware F.  
(Repeat 1 times for each hardware.)

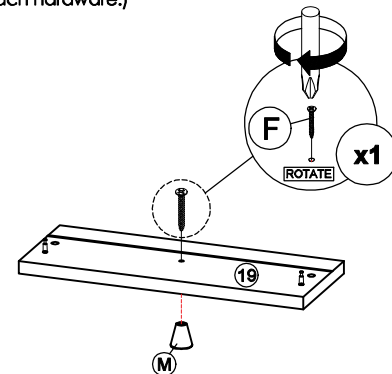

**STEP 21**

Assemble panel (20) with panel (21) and (22) by using hardware G.  
(Repeat 4 times.)

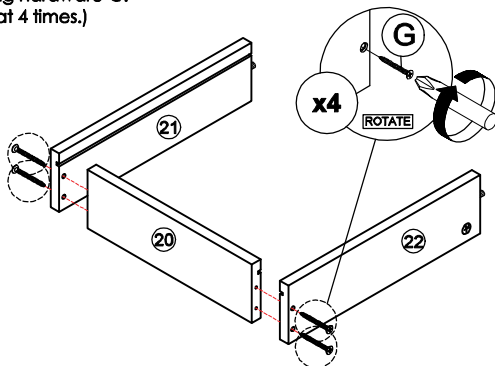

**STEP 22**

Insert the panel (23) along the slot.  
(Repeat 1 times.)

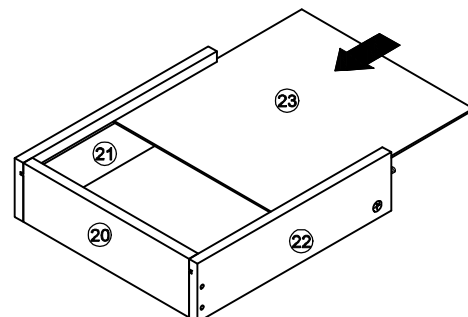

CODING  
- 124070

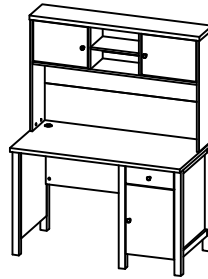

ISO 9001:2015  
Reg. No. 00705-1-ACEY-1-0003

nuhoom.com

### STEP 23

- Attach panel (19) to panel (21) and (22).
- Insert all hardware A2 into A1.
- Rotate all A1 until tight.
- Apply A3 onto all A1.  
(Repeat 2 times.)

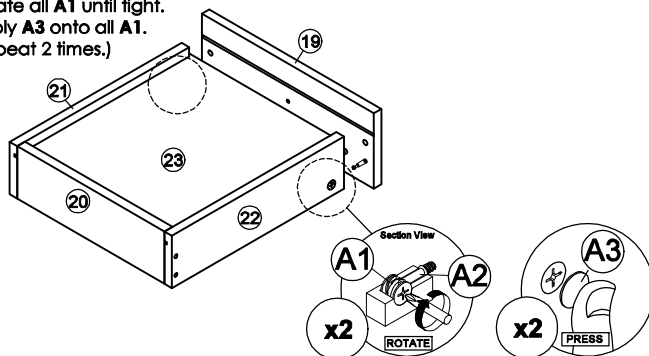

\* In this step hardware A1, A2 and B are pre-inserted.

### STEP 25

- Put all the drawer in place along the drawer slides.

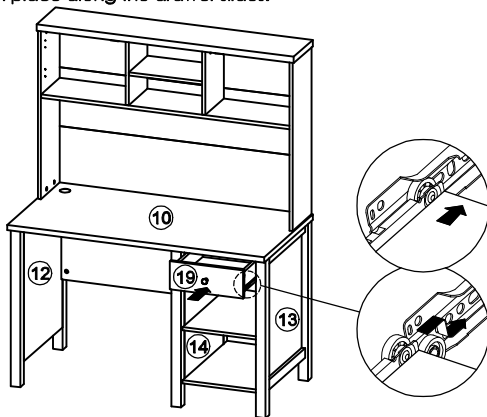

### STEP 27

- Fix hardware M onto panel (9) and (18) by using hardware F.
- (Repeat 1 times for each hardware.)
- Fix hardware K onto panel (9) and (18) by using hardware E.
- (Repeat 2 times for each hardware.)

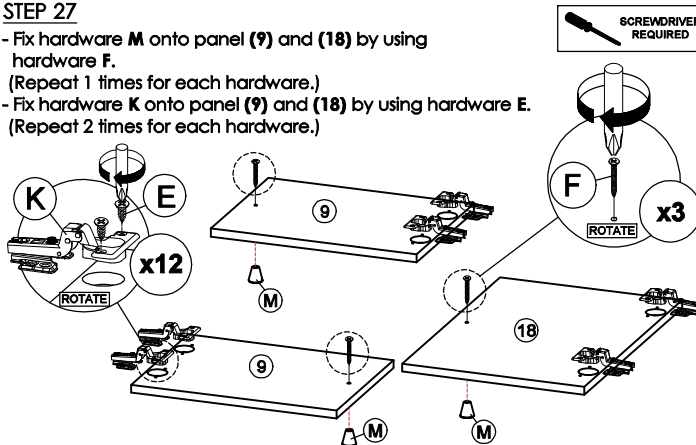

### STEP 24

- Assemble hardware N2 (L/R) to panel (21) and (22) by using hardware E.
- (Repeat 3 times for each hardware.)

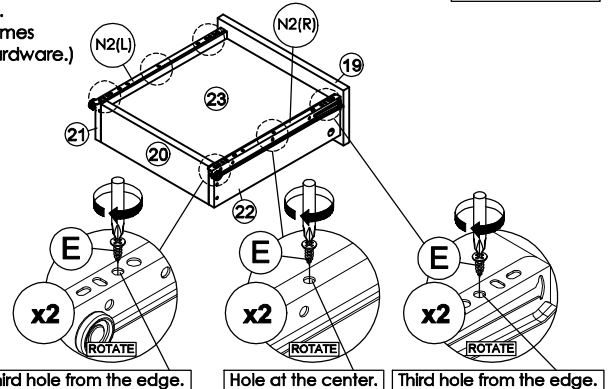

\*Hardware N2 (L/R) shall be leaning against panel (19) when assembling.

### STEP 26

- Insert hardware L into mounting positions on panel (10) by hand.
- (Repeat 1 times.)

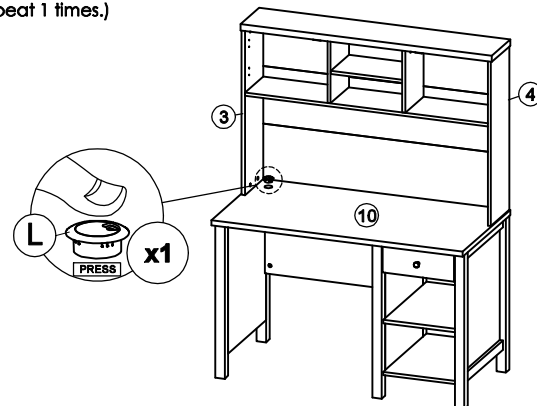

### STEP 28

- Fix hardware K onto panel (3), (4) and (13) by using hardware E.
- (Repeat 4 times for each hardware.)
- Tighten or loosen the screw to adjust position of panel (9) and (18).
- (Do only when needed.)

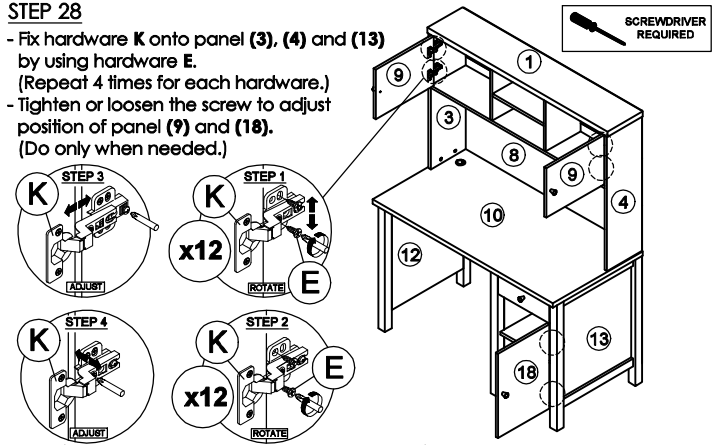

\* In this step hardware K have been assembled in panel (9) and (18).