

CODING
- 124058

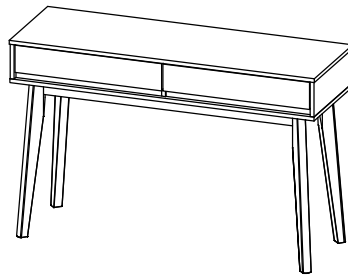

ISO 9001:2015
Reg. No. 000435-1-MY-1-QMS

nuhoom.com

Read the instructions carefully. Remove all the wrappings , staples and straps from the carton. Refer to the hardware and furniture part list for guidance. Make sure that you have all the parts before you start assembling. Place all the wooden furniture parts on a clean, flat and soft surface, such as a carpet or rubbermat to prevent scratches.

CAUTION
KEEP ALL THE PARTS OUT OF CHILDREN'S REACH.

PART LIST		QTY
1	TOP PANEL	1 PC
2	BOTTOM PANEL	1 PC
3	SIDE PANEL (L)	1 PC
4	SIDE PANEL (R)	1 PC
5	CENTER PANEL	1 PC
6	BONE PANEL	2 PCS
7	BACK PANEL	1 PC
8	DRAWER FRONT (L)	1 PC
9	DRAWER FRONT (R)	1 PC
10	DRAWER BACK	2 PCS
11	DRAWER SIDE	4 PCS
12	DRAWER BOTTOM	2 PCS
13	CABINET LEG	4 PCS

HARDWARE			
A	MINI FIX	A1 A2 A3	6 SETS
B	M8 X 30MM WOOD DOWEL		16 PCS
C	M6 X 50MM CSK CAP WOOD SCREW		6 PCS
D	ALLEN KEY M4		1 PC
E	M3.5 X 16MM C.B SCREW		24 PCS
F	M4 X 38MM C.B SCREW		22 PCS
G	5/8 NAIL		16 PCS
H	JCBC Screw M6 x 70		8 PCS
I	SPRING WASHER M6		8 PCS
J	FLAT WASHER M6		8 PCS
K	14" DRAWER SLIDE	K1 (L/R) K2 (L/R)	2 SETS

SELF-PREPARED TOOLS: Tools below are NOT included in package.	
	SCREWDRIVER
	HAMMER

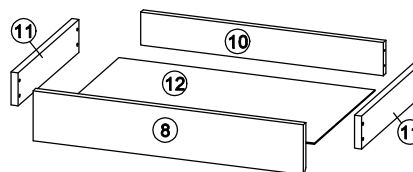
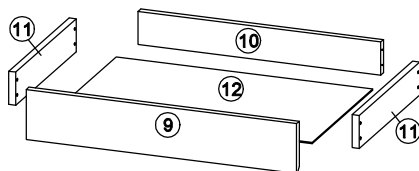
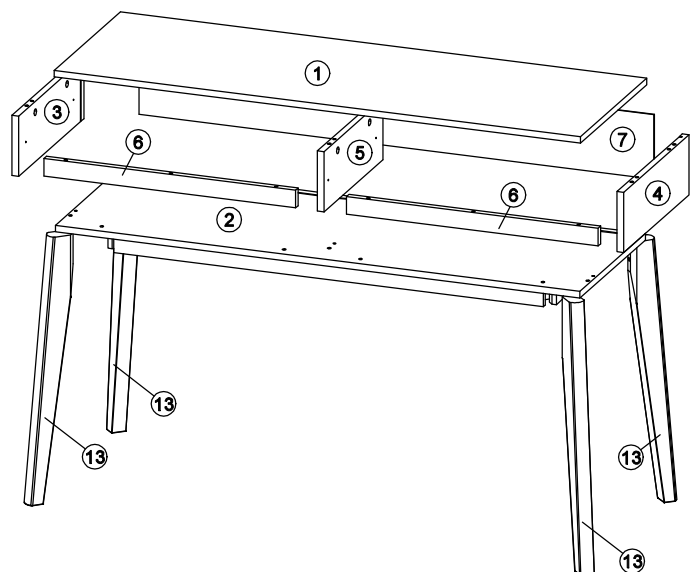

CODING
- 124058

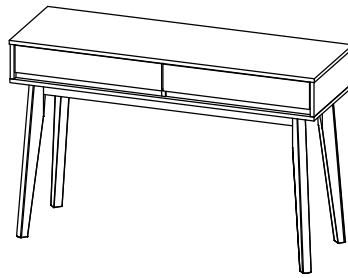

ISO 9001:2015
Reg. No. 070435-1-MY-1-QM

nuhoom.com

STEP 1

- Insert hardware **A1** onto panel (3), (4) and (5). (Repeat 6 times.)
- Insert hardware **A2** onto panel (1). (Repeat 6 times.)
- Insert hardware **B** onto panel (3), (4), (5) and (6). (Repeat 16 times.)

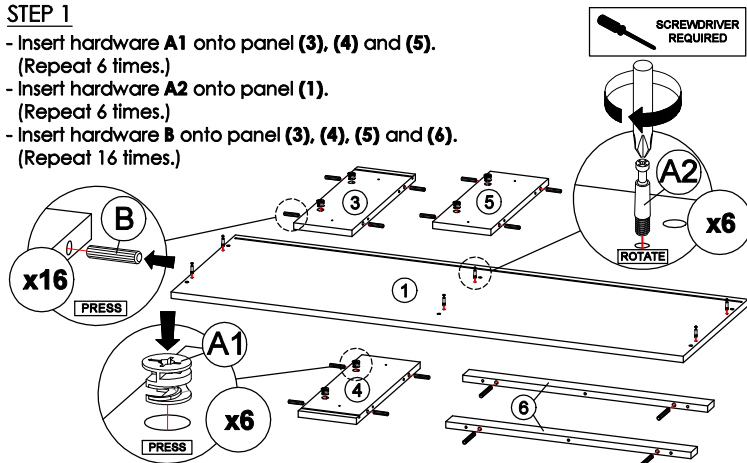

* Ensure the arrows on hardware **A1** point towards mounting positions.

STEP 3

- Fix hardware **K1 (R)** into panel (5) with hardware **E**. (Repeat 3 times for each hardware.)

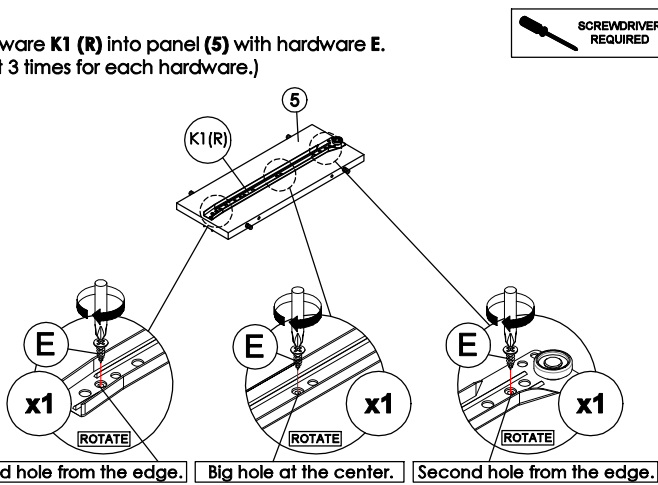

Second hole from the edge. Big hole at the center. Second hole from the edge.

STEP 5

- Insert the panel (7) along the slot. (Repeat 1 times.)

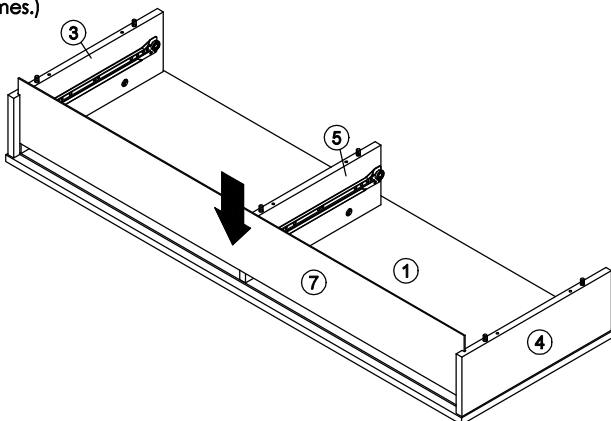

STEP 2

- Fix hardware **K1 (L/R)** into panel (3), (4) and (5) with hardware **E**. (Repeat 3 times for each hardware.)

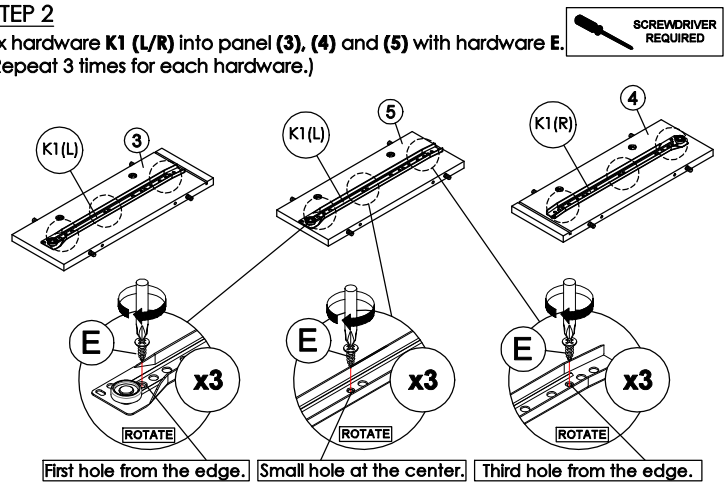

First hole from the edge. Small hole at the center. Third hole from the edge.

STEP 4

- Attach panel (3), (4) and (5) to panel (1).
- Insert all hardware **A2** into **A1**.
- Rotate all **A1** until tight.
- Apply **A3** onto all **A1**. (Repeat 6 times.)

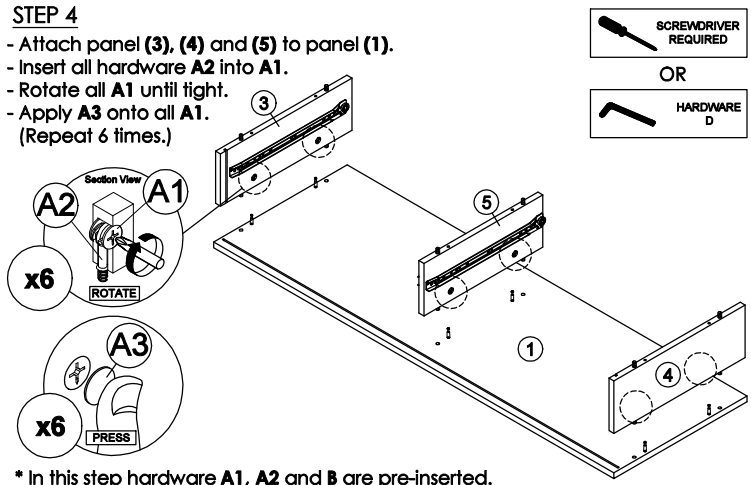

* In this step hardware **A1**, **A2** and **B** are pre-inserted.

STEP 6

- Assemble panel (6) to panel (2) by using hardware **F**. (Repeat 6 times.)

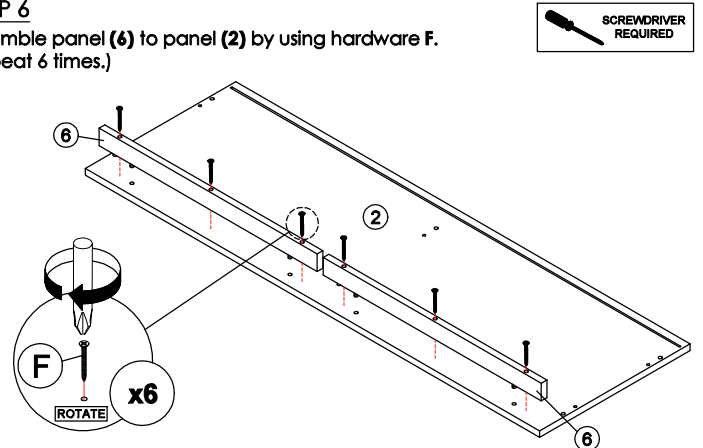

CODING
- 124058

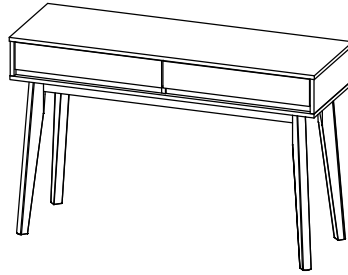

ISO 9001:2015
Reg. No. 07035-1-MY-1-QMS

nuhoom.com

STEP 7

Connect panel (2) to panel (3), (4) and (5) by using hardware C and D. (Repeat 6 times.)

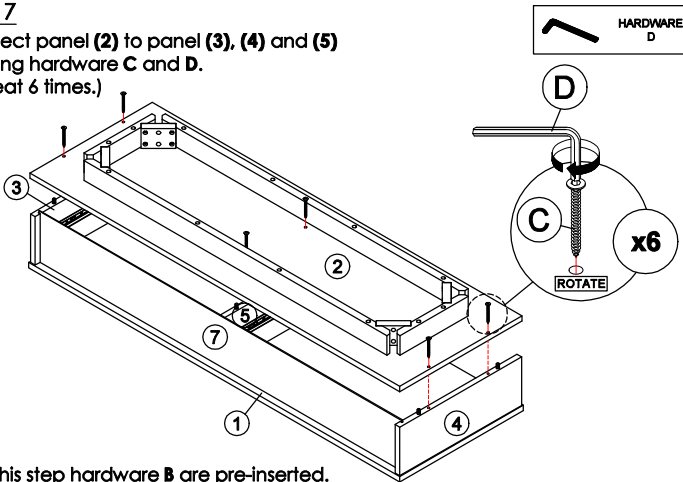

* In this step hardware B are pre-inserted.

STEP 9

Assemble panel (11) with panel (8) or (9) and (10) by using hardware F. (Repeat 16 times.)

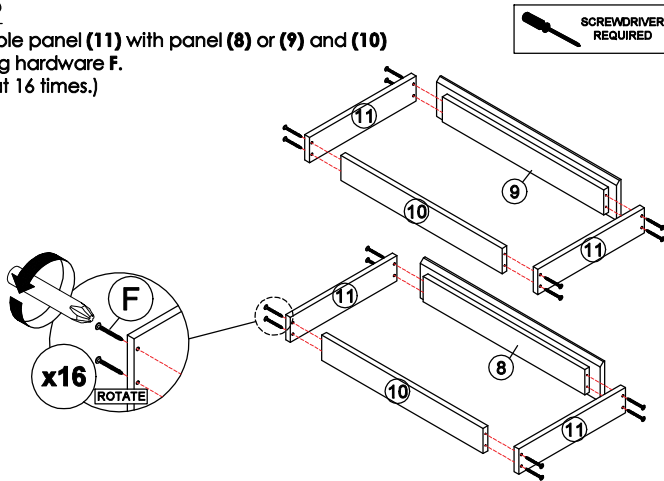

STEP 8

Assemble part (13) into panel (2) by using hardware D, H, I and J. (Repeat 2 times for each Leg.)

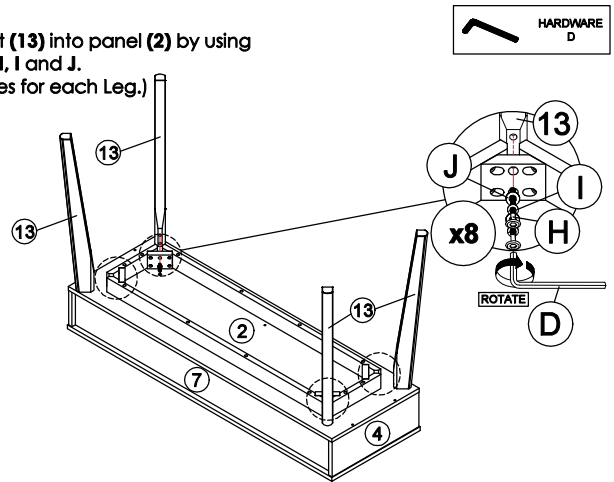

STEP 10

Assemble panel (12) to entire body with hardware G. (Repeat 16 times.)

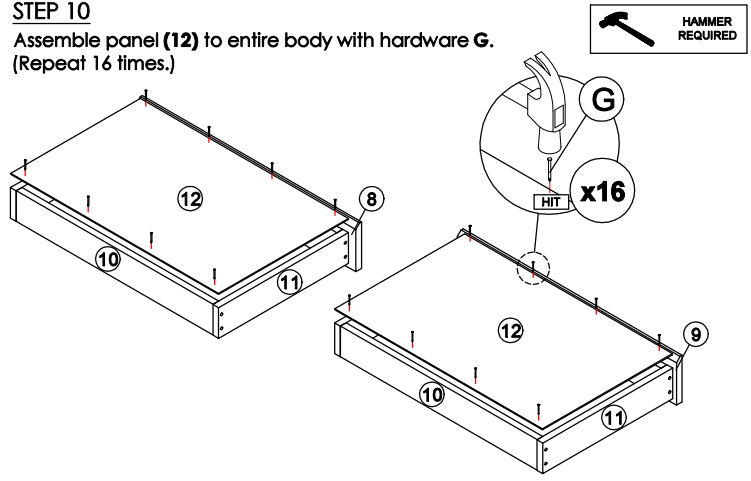

STEP 11

Assemble hardware K2 (L/R) to panel (12) by using hardware E. (Repeat 3 times for each hardware.)

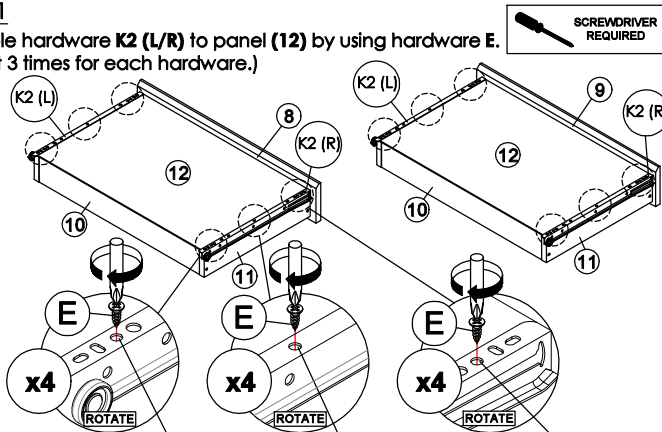

STEP 12

Put all the drawer in place along the drawer slides.

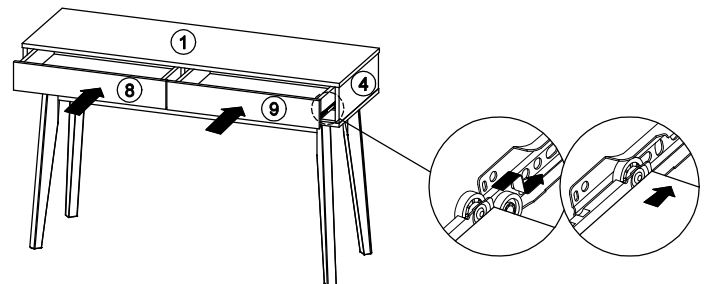

Third hole from the edge. Hole at the center. Third hole from the edge.

*Hardware K2 (L/R) shall be leaning against panel (8) or (9) when assembling.